

DWG. NO.	096-6017		
SIZE	D		
REVISIONS			
SYM.	E.C.O.	DATE	APVD.
A	27508	10/28/11	ADDED 65KVA UPS

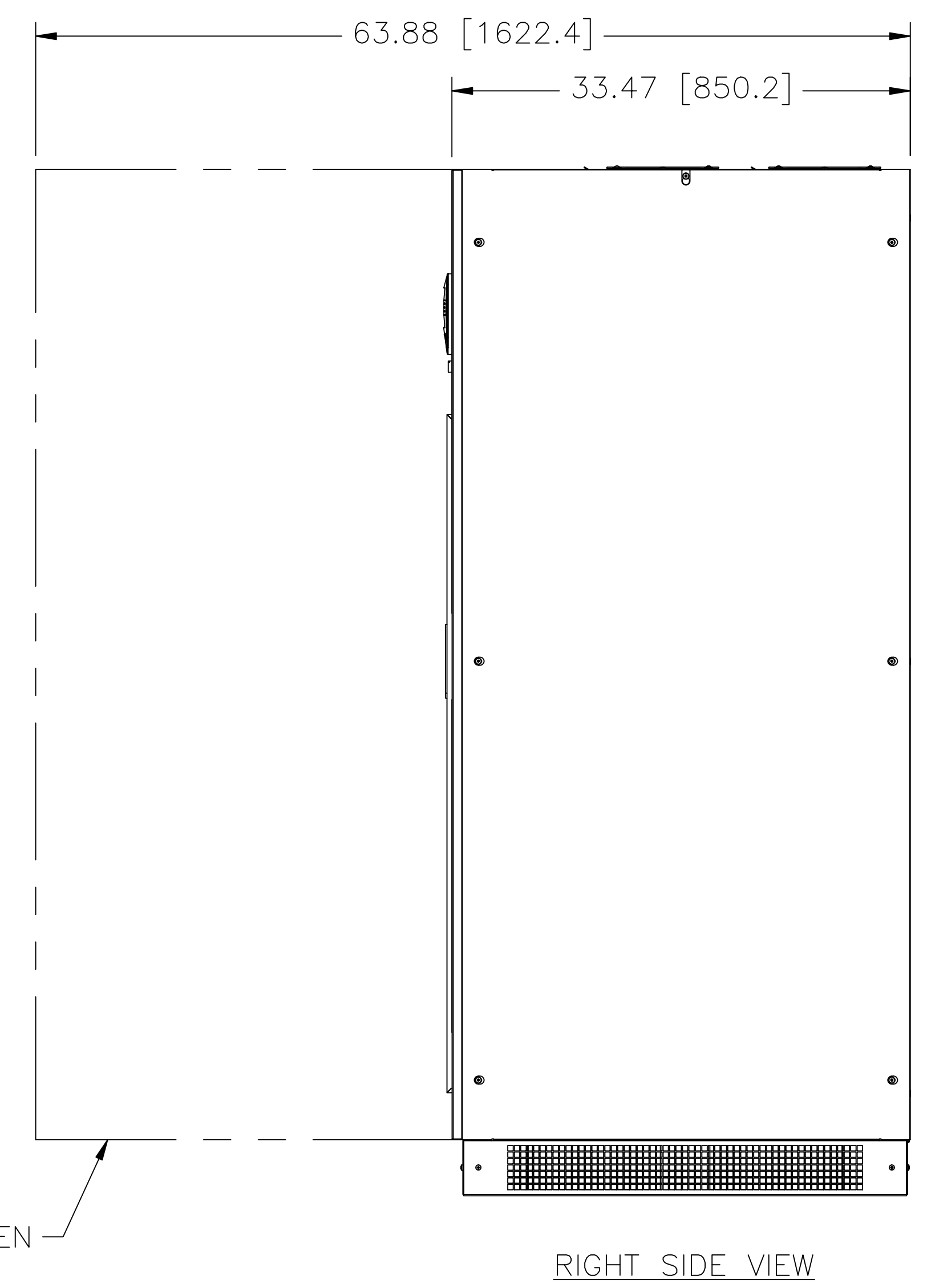
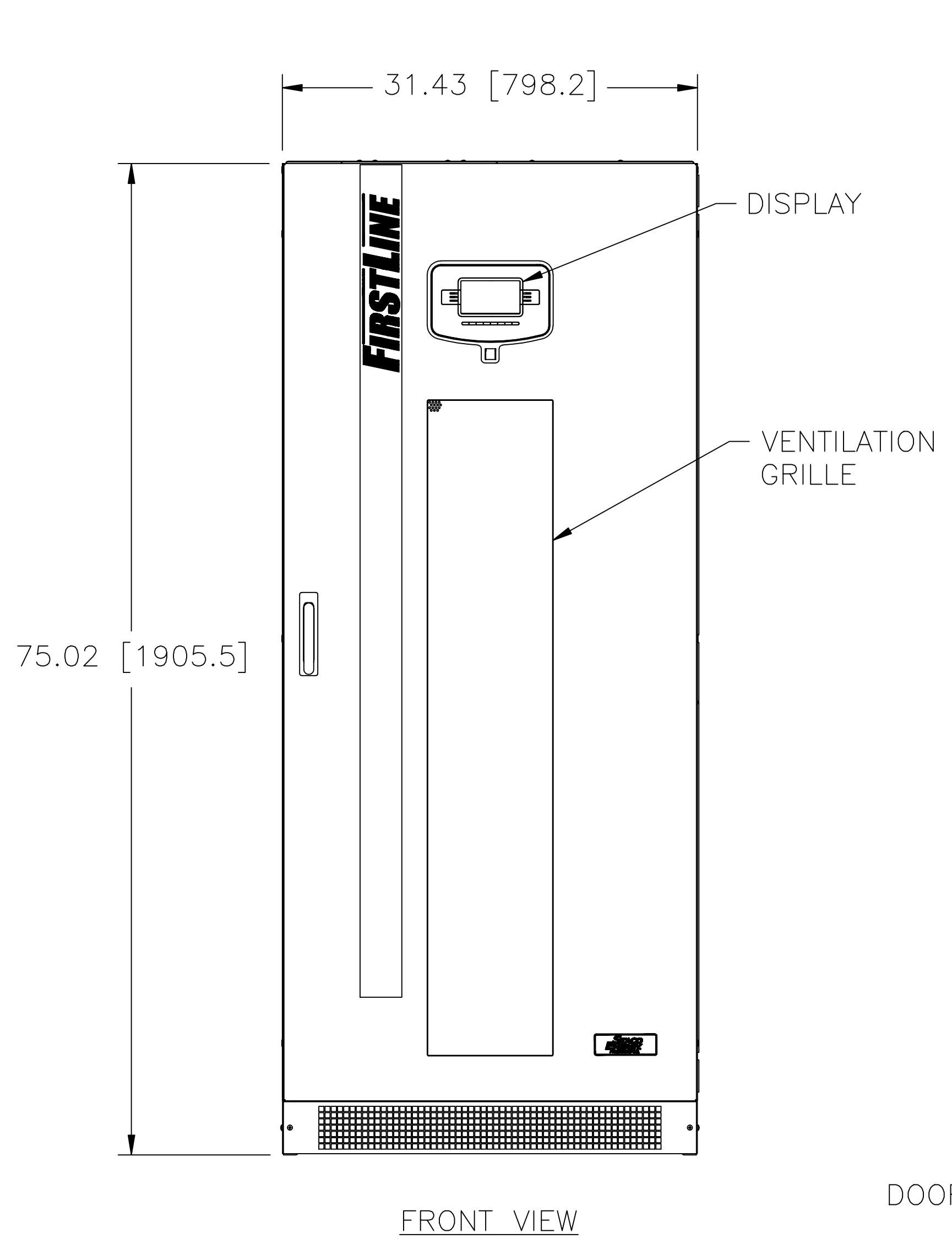

SUMMARY OF EQUIPMENT

THE FIRSTLINE P UNINTERRUPTIBLE POWER SUPPLY (UPS) IS A TRUE ON-LINE, DOUBLE CONVERSION, PARALLELABLE, THREE PHASE SYSTEM THAT CAN PREVENT THE LOSS OF ELECTRONIC INFORMATION AND MINIMIZE EQUIPMENT DOWN TIME.

THE FIRSTLINE P UPS CONSTANTLY MONITORS THE INCOMING ELECTRICAL POWER AND PROTECTS THE CONNECTED LOAD BY REMOVING VOLTAGE SPIKES, SAGS, TRANSIENTS, AND OTHER DAMAGING IRREGULARITIES THAT ARE COMMON IN COMMERCIAL UTILITY POWER. THE UPS SUPPLIES THE CLEAN, CONSISTENT POWER THAT SENSITIVE ELECTRONIC EQUIPMENT REQUIRES FOR RELIABLE OPERATION. DURING BROWNOUTS, BLACKOUTS, AND OTHER POWER INTERRUPTIONS, THE BATTERIES PROVIDE EMERGENCY POWER TO SAFEGUARD OPERATION.

THE FRONT DISPLAY PANEL PROVIDES ACCESS TO DETAILED INFORMATION REGARDING THE STATUS OF THE UTILITY, LOAD, AND FIRSTLINE UPS.

THE BLOCK DIAGRAM BELOW SHOWS THE MAIN FUNCTIONAL SUBASSEMBLIES OF THE FIRSTLINE P UPS. THE AC THREE PHASE UTILITY SUPPLY IS RECTIFIED TO PROVIDE DIRECT CURRENT, THE INVERTER WHICH PROVIDES THE THREE PHASE OUTPUT, AND ELECTRONIC STATIC SWITCH.

PROVIDED THE UTILITY IS WITHIN LIMITS, THE INVERTER WILL MATCH THE OUTPUT FREQUENCY WITH THE UTILITY FREQUENCY. THE INVERTER HAS ITS OWN INTERNAL CONTROL TO STABILIZE THE OUTPUT FREQUENCY IF THE UTILITY FREQUENCY IS OUT OF LIMITS. THE ELECTRONIC STATIC SWITCH SWITCHES THE OUTPUT FROM THE INVERTER TO THE UTILITY, WITHOUT INTERRUPTION, TO MEET ANY LOAD CURRENT SURGES.

UPS CAN BE CONFIGURED FOR WYE-WYE OR DELTA-DELTA APPLICATIONS. DELTA-WYE APPLICATIONS REQUIRE EXTERNAL TRANSFORMER.

ENVIRONMENTAL

- OPERATING TEMPERATURE: 0°C TO 40°C
- ALTITUDE: 0-3300 FEET [1000 METERS] (WITHOUT DERATING)
- RELATIVE HUMIDITY: 0-95%, NON-CONDENSING

SERVICE/VENTILATION CLEARANCES

- FROM TOP OF CABINET: 24.00 [609.6]
- FROM FRONT OF CABINET: 36.00 [914.4]
- FROM ONE SIDE OF CABINET (RIGHT, LEFT OR REAR): 24.00 [609.6]

UL LISTED TO UL 1778, FILE NO.: E191175

MODEL	kVA	INPUT VOLTAGE (+10%, -20%) 60 HZ	OUTPUT VOLTAGE (±1%) 60 HZ	MAXIMUM INPUT CURRENT (AMPS)	NOMINAL OUTPUT CURRENT (AMPS)
FLU-65-00	65	480Y/277	480Y/277	89	78.2
FLU-80-00	80	480Y/277	480Y/277	109	96.3
FLU-100-00	100	480Y/277	480Y/277	136	120.3
FLU-125-00	125	480Y/277	480Y/277	160	150.4

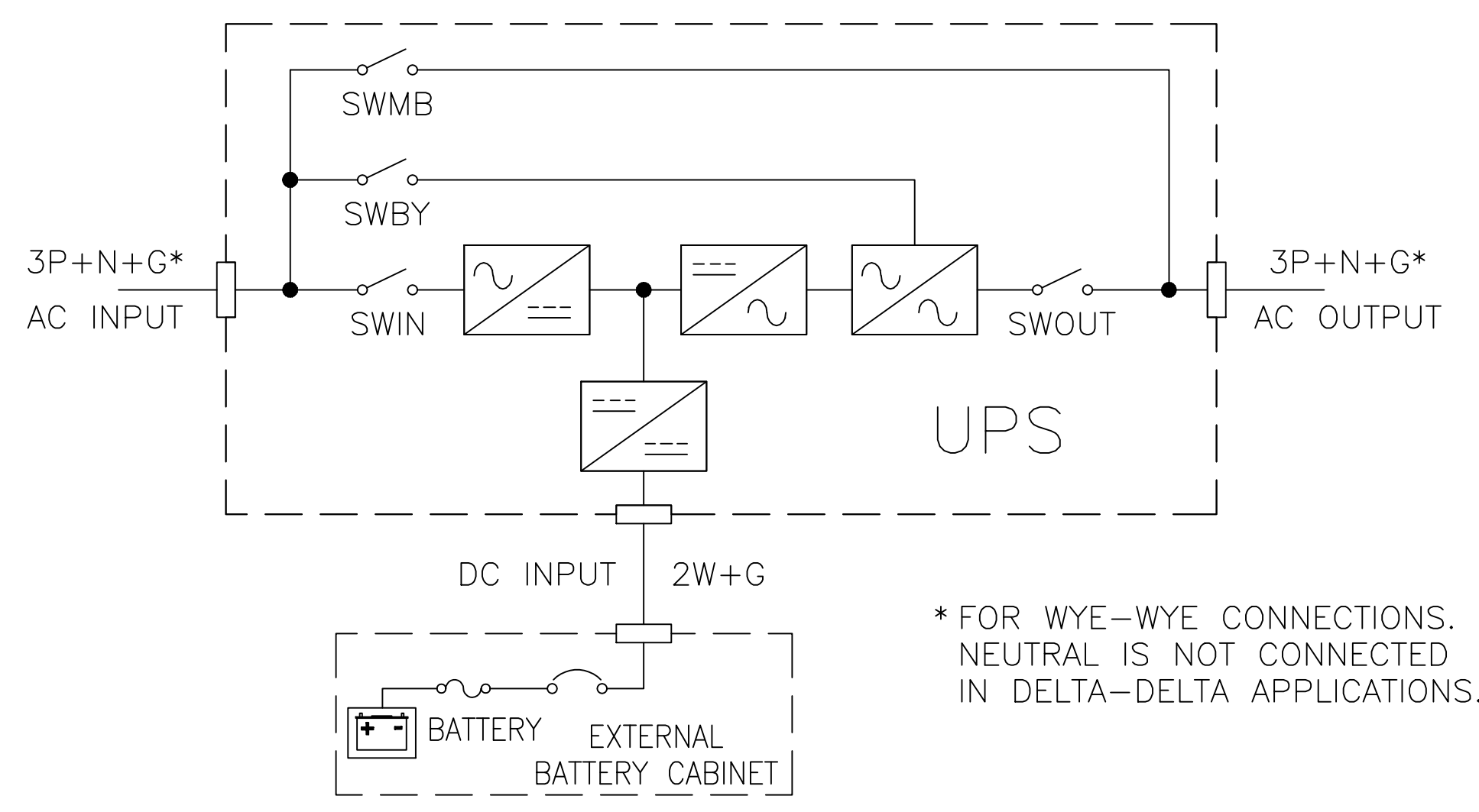
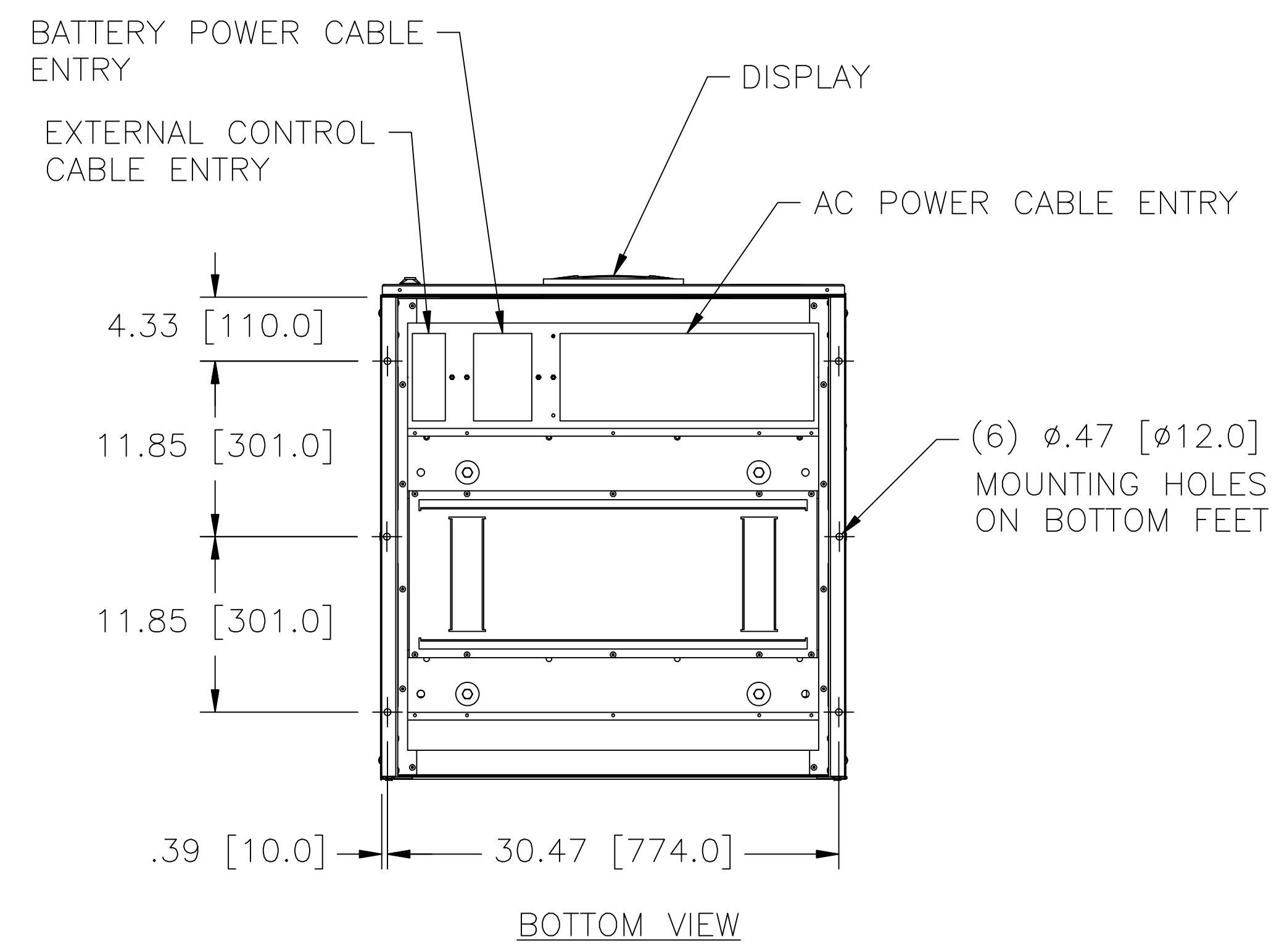

* FOR WYE-WYE CONNECTIONS. NEUTRAL IS NOT CONNECTED IN DELTA-DELTA APPLICATIONS.

NOTE: AC AND DC CABLES PROVIDED BY OTHERS. CABLE LUGS PROVIDED BY OTHERS.

UNLESS OTHERWISE SPECIFIED, TOLERANCE IS #		UNITS		TITLE: SPECIFICATION CONTROL DRAWING	
DIMENSIONAL	HOLES	ANGLES	DRAFT	FIRST LINE P UPS	
.XX	.000	1°	1-1/2°	UNINTERRUPTIBLE POWER SUPPLY	
.XXX	.005			DRAWN BY: S.A. SMITH	
MATERIAL:				DATE: 11/11/10	
ALL DIMENSIONS APPLY AFTER PLATING				FIRST USED ON:	
The information and design disclosed herein was originated by and is the property of STACO ENERGY PRODUCTS CO., which reserves all patent, proprietary, design, manufacturing, reproduction, use and sale rights therein, and to any article disclosed therein except to the extent rights are expressly granted to others. The foregoing does not apply to vendor proprietary parts.				DO NOT SCALE DWG.	
				CHECKER: SAS	
				DATE: 11/11/10	
				WEIGHT APPROX.:	
				ENGINEER: R. BAKER	
				SCALE: 1/8	
				CAGE CODE: 83008	
				SHEET 1 OF 3	
				DWG. NO. 096-6017	



DWG. NO.	096-6017		
SIZE	D		
REVISIONS			
SYM.	E.C.O.	DATE	APVD.
A	27508	10/28/11	ADDED 65KVA UPS

UPS 100-125kVA
CONNECTIONS

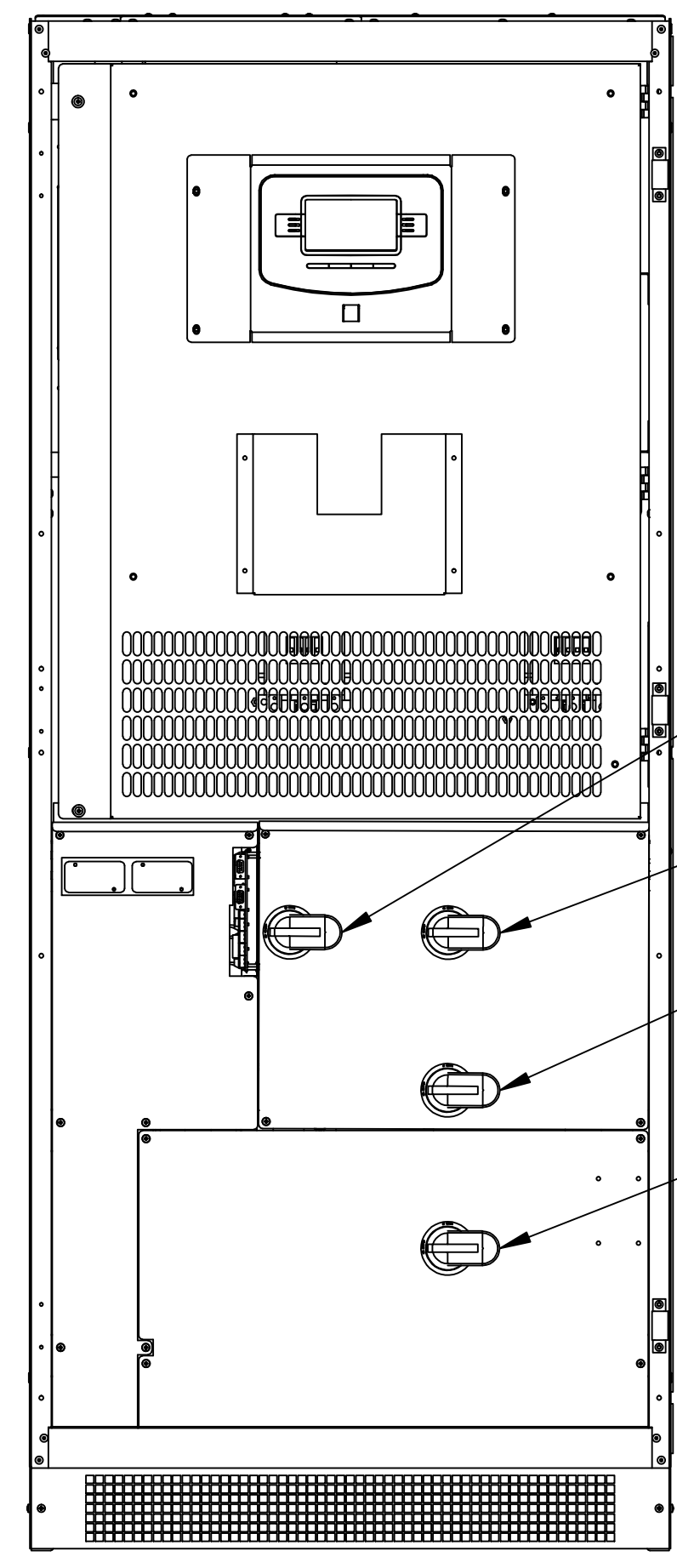

SWIN
SWOUT
SWMB
SWBY

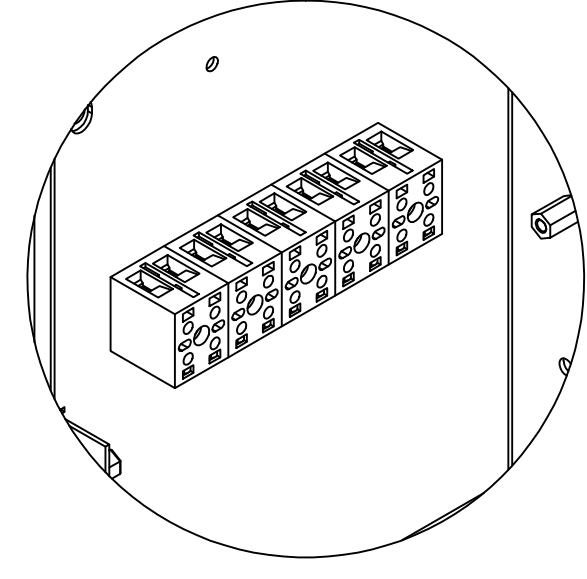

AUX CONNECTIONS
DETAIL F

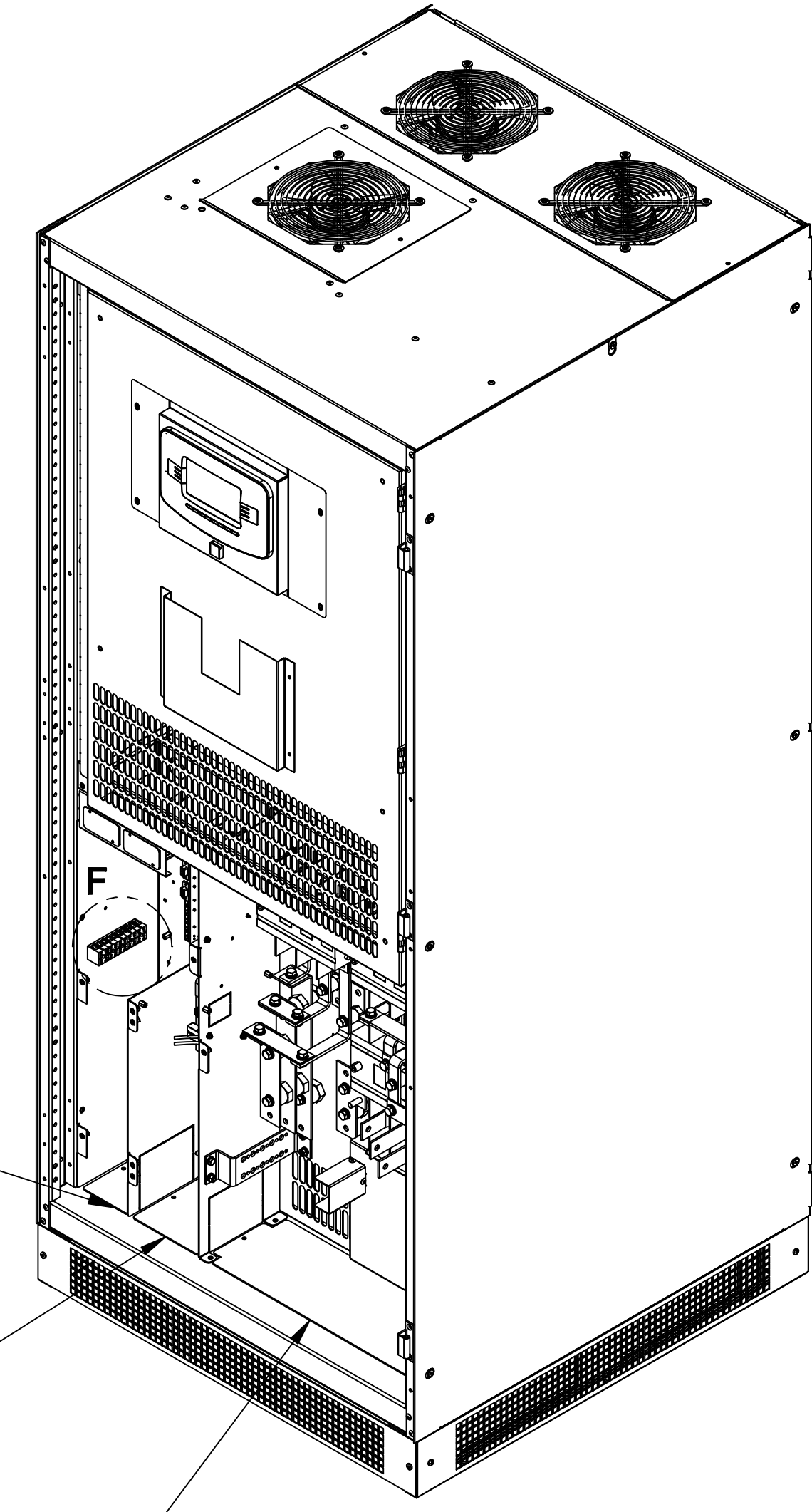

AUX CABLE ENTRY
CONDUIT LANDING
PLATE
BATTERY CABLE ENTRY
CONDUIT LANDING
PLATE
POWER CABLE ENTRY
CONDUIT LANDING
PLATE

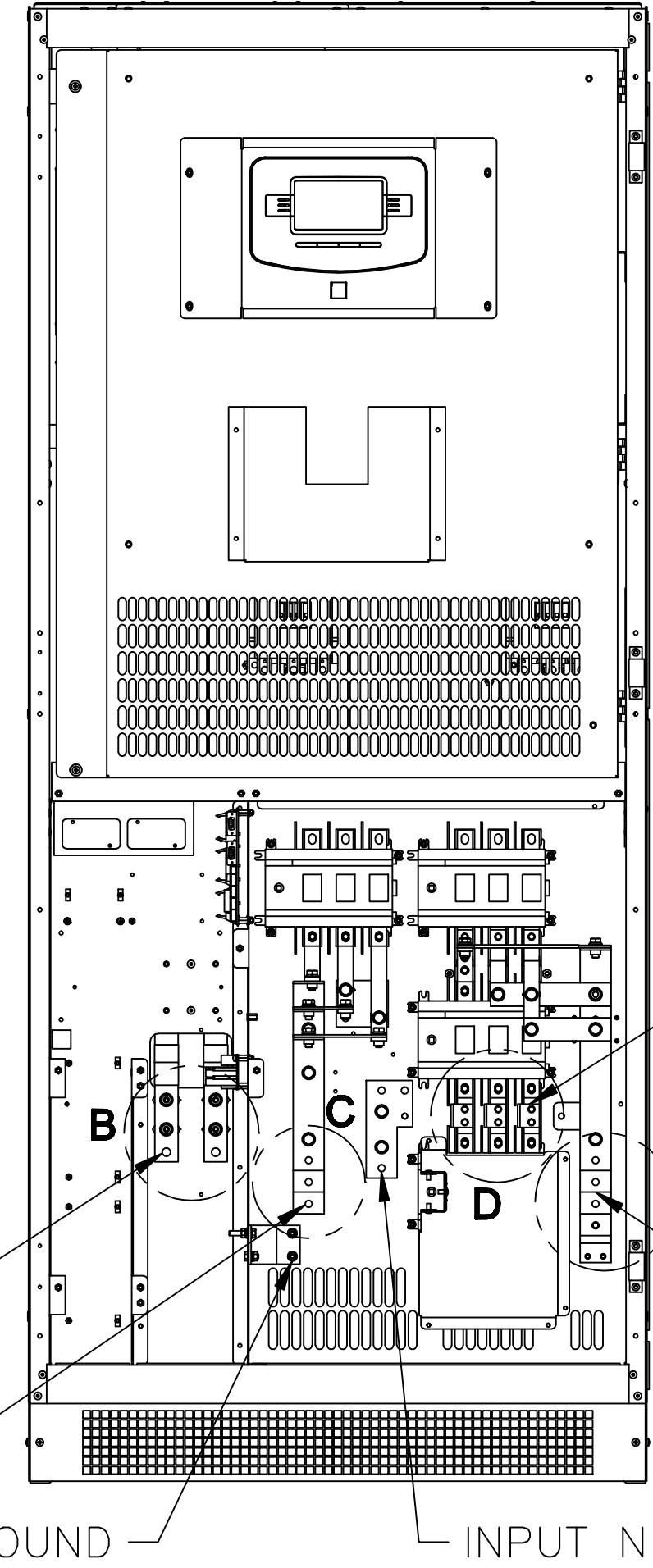

BYPASS
BATTERY
INPUT
GROUND
INPUT N
OUTPUT

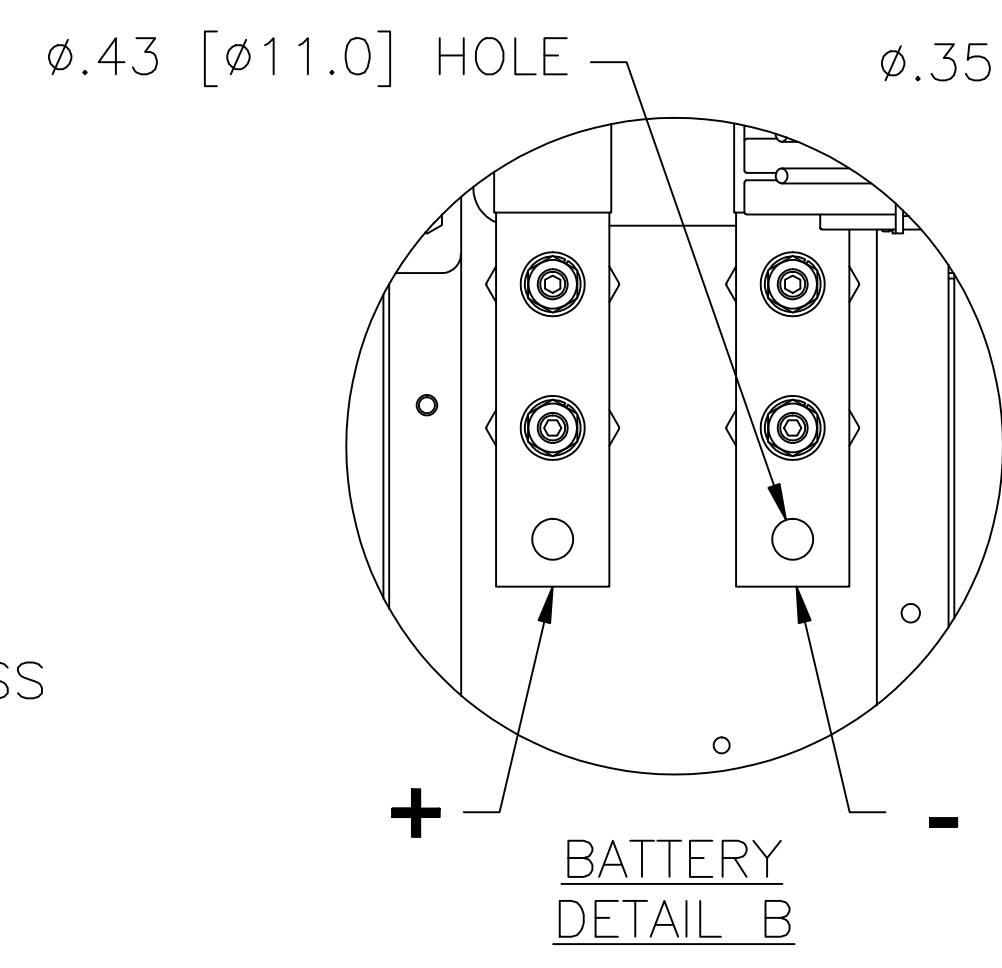

0.43 [011.0] HOLE
+ BATTERY
DETAIL B -

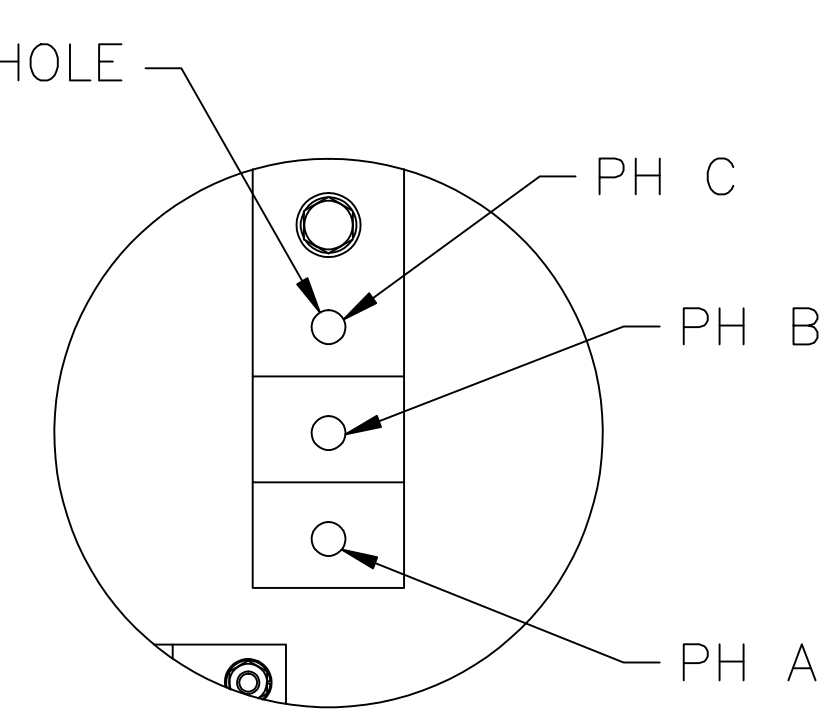

0.35 [09.0] HOLE
PH C
PH B
PH A
INPUT
DETAIL C

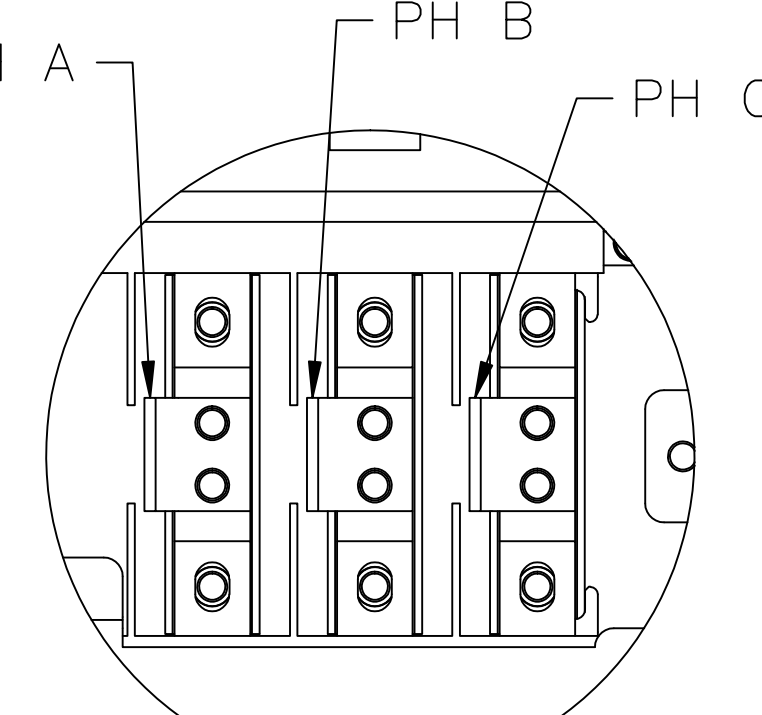

PH A
PH B
PH C
BYPASS
DETAIL D

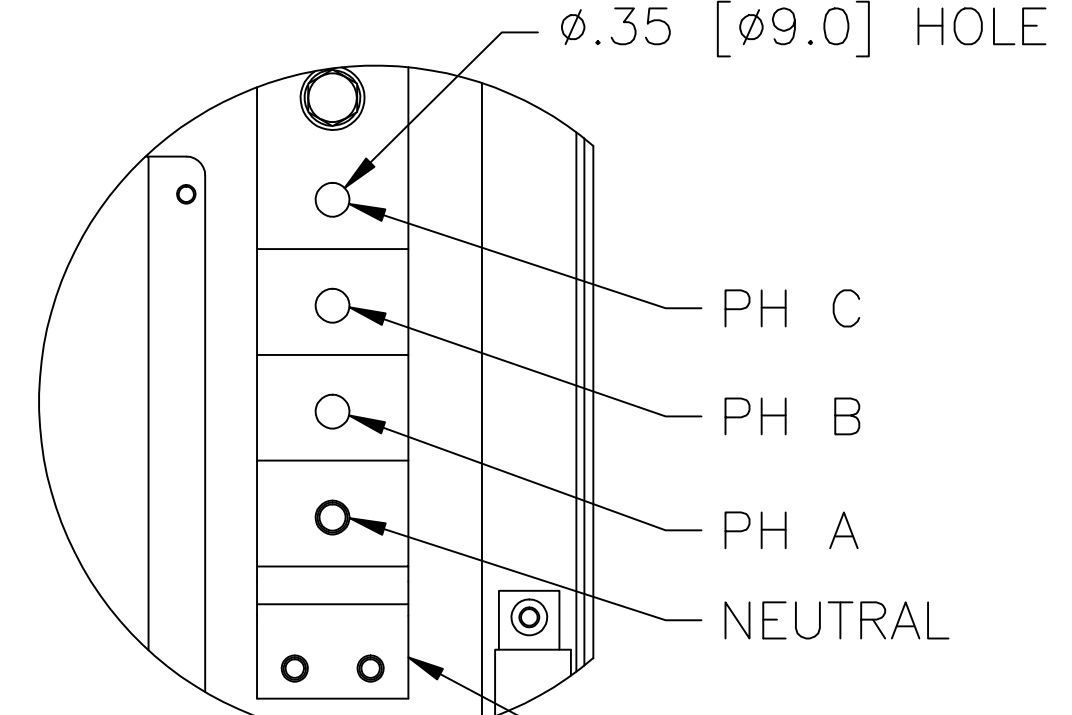

0.35 [09.0] HOLE
PH C
PH B
PH A
NEUTRAL
BOND (REMOVE FOR
WYE APPLICATIONS)
OUTPUT
DETAIL E

UNLESS OTHERWISE SPECIFIED, TOLERANCE IS #		UNITS		TITLE: SPECIFICATION CONTROL DRAWING	
DECIMALS	HOLES	ANGLES	DRAFT	FIRSTLINE P UPS	
.XX .010 .06	.005	1°	1-1/2°	UNINTERRUPTIBLE POWER SUPPLY	
.XXX .005				DRAWN BY: S.A. SMITH	
MATERIAL:				DATE: 11/11/10	
ALL DIMENSIONS APPLY AFTER PLATING				FIRST USED ON:	
The information and design disclosed herein was originated by and is the property of STACO ENERGY PRODUCTS CO., which reserves all patent, proprietary, design, manufacturing, reproduction, use and sale rights therein, and to any article disclosed therein except to the extent rights are expressly granted to others. The foregoing does not apply to vendor proprietary parts.				DO NOT SCALE DWG.	
CHECKER: SAS		DATE: 11/11/10		WEIGHT APPROX.:	
ENGINEER: R. BAKER		DATE: 1/17/11		SCALE: 1/8	
				CAGE CODE: 83008	
				SHEET 2 OF 3	
				DWG. NO. 096-6017	



DWG. NO.	096-6017		
SIZE	D		
REVISIONS			
SYM.	E.C.O.	DATE	APVD.
A	27508	10/28/11	ADDED 65KVA UPS

UPS 65-80kVA
CONNECTIONS

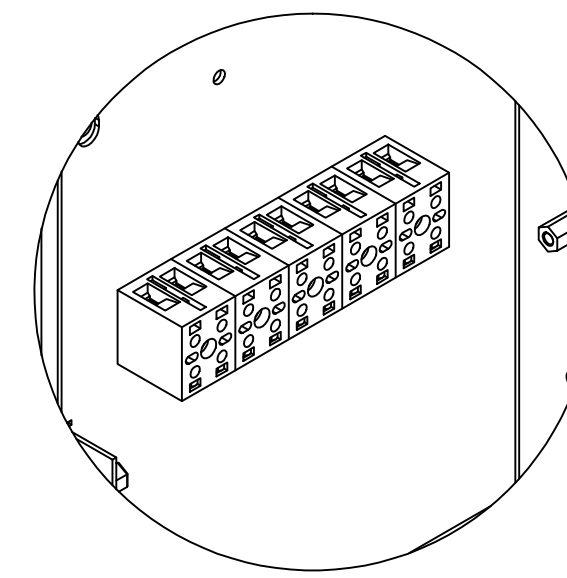
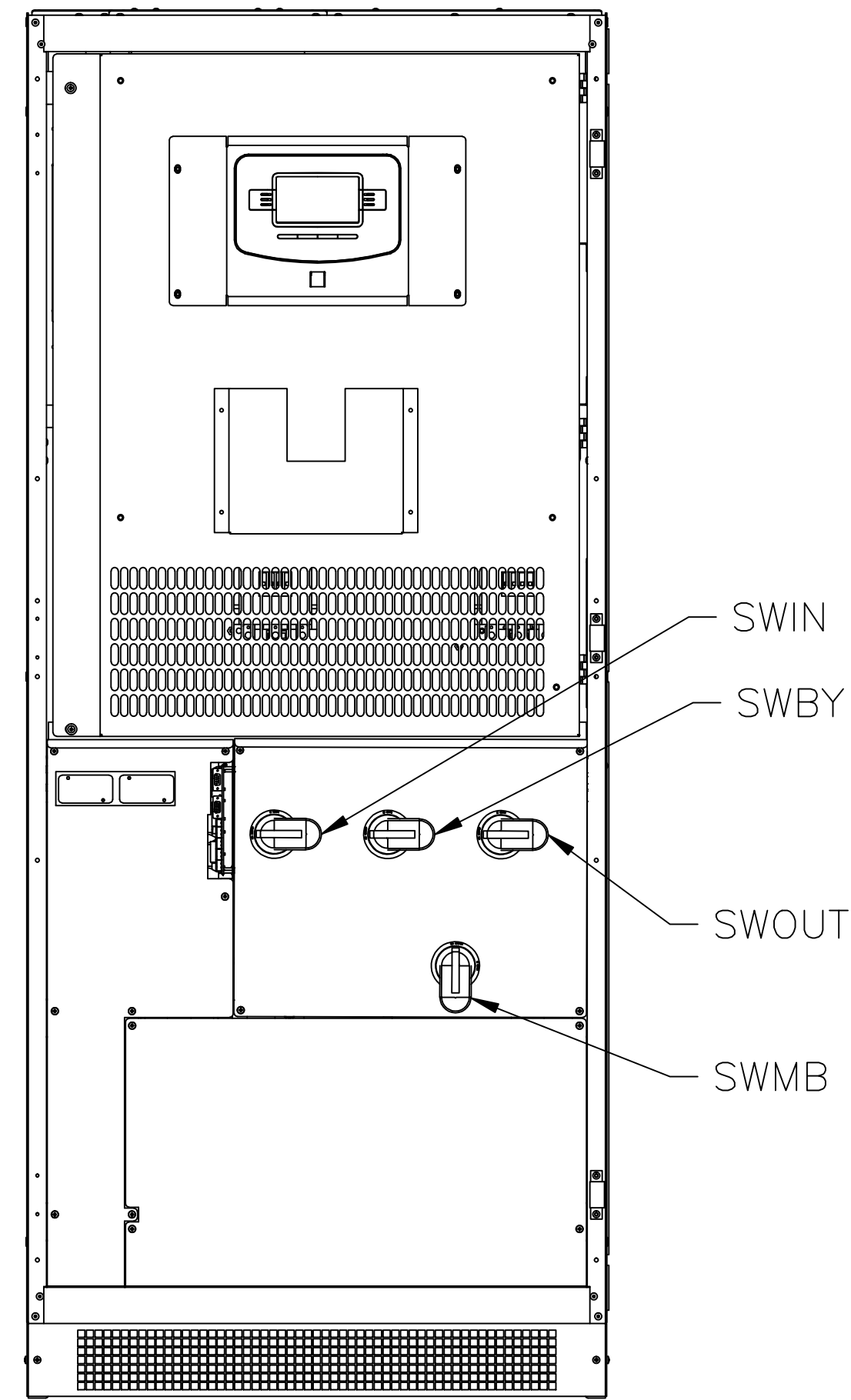

AUX CONNECTIONS
DETAIL M

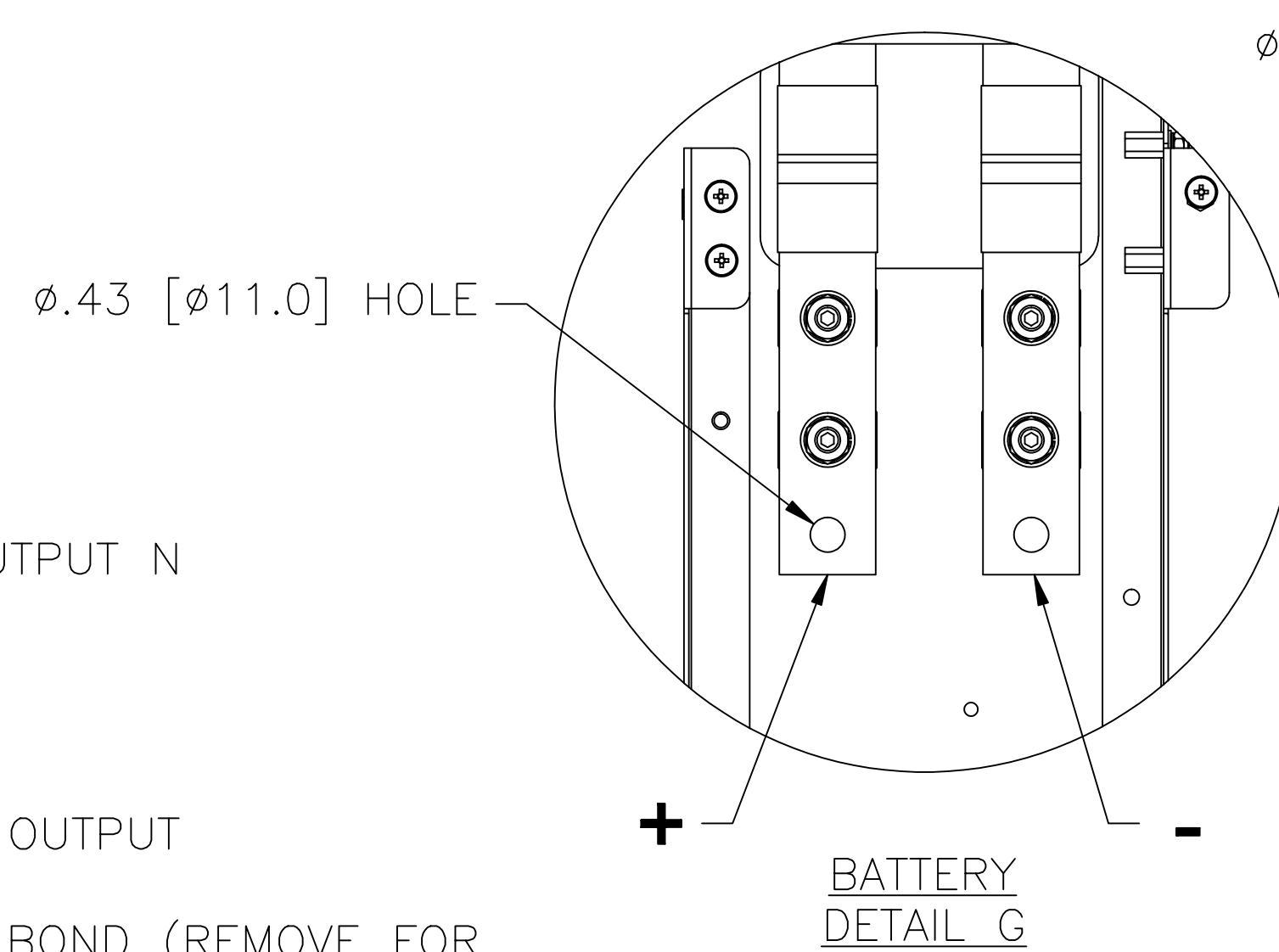
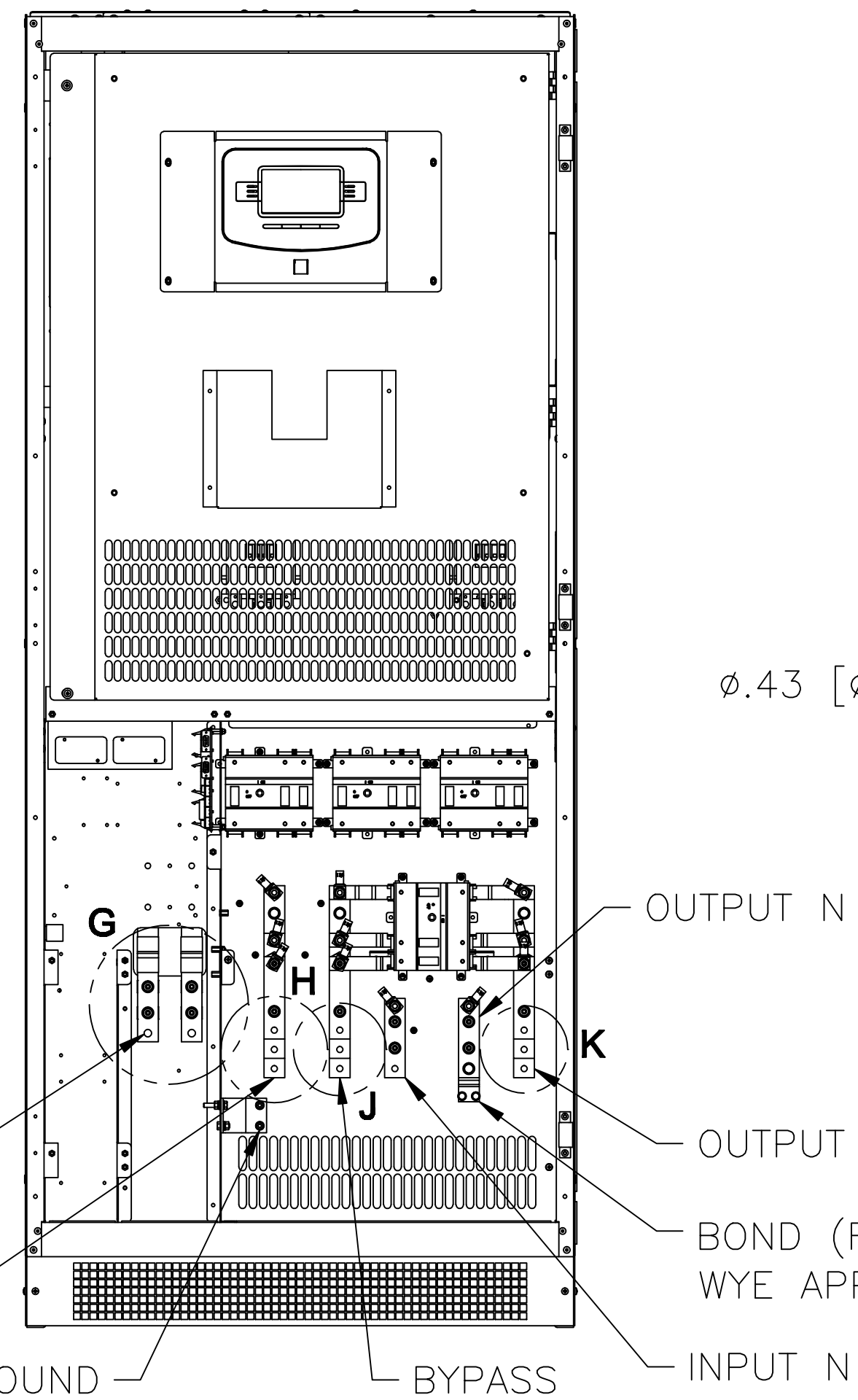
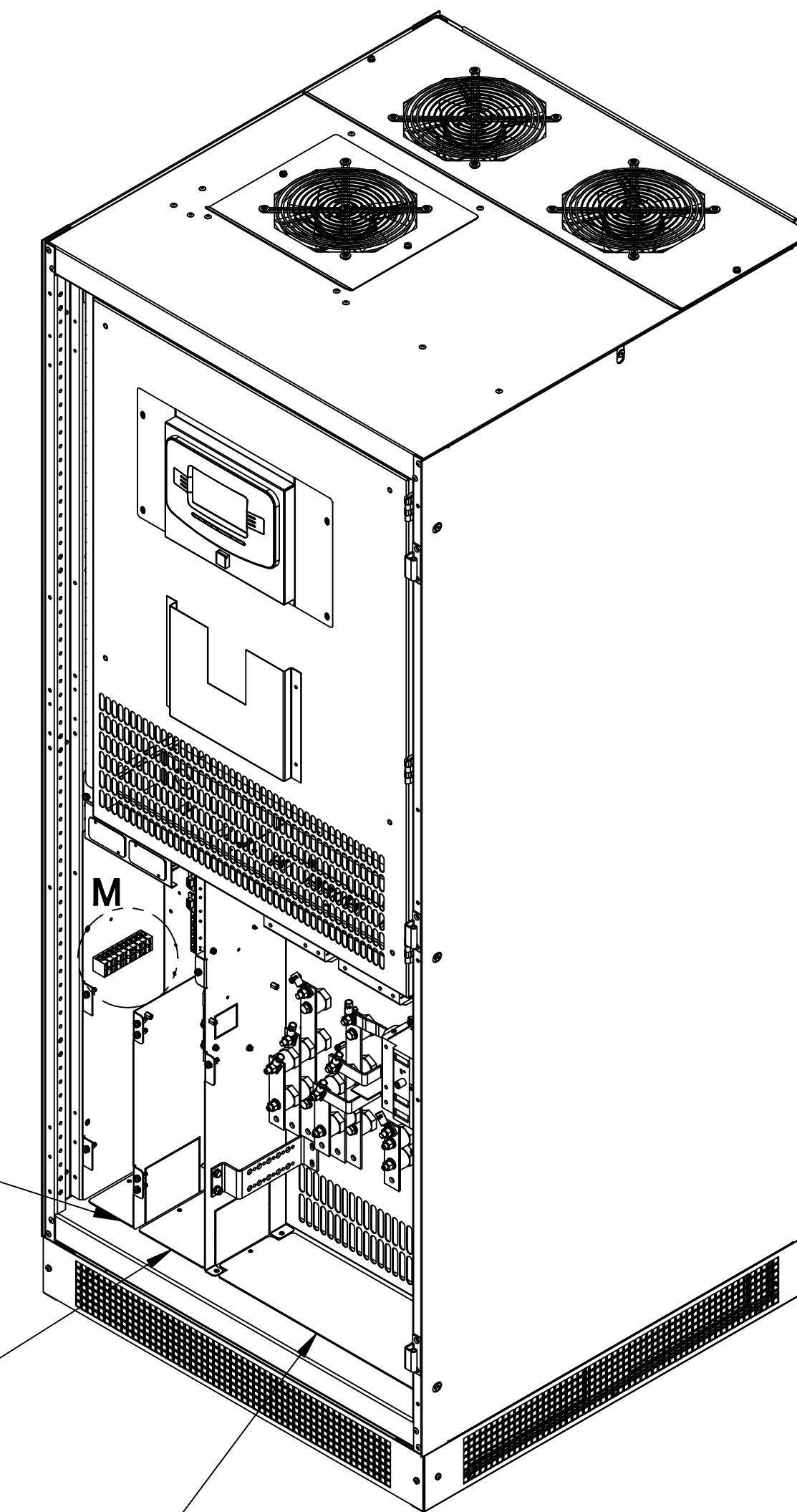

BATTERY
DETAIL G

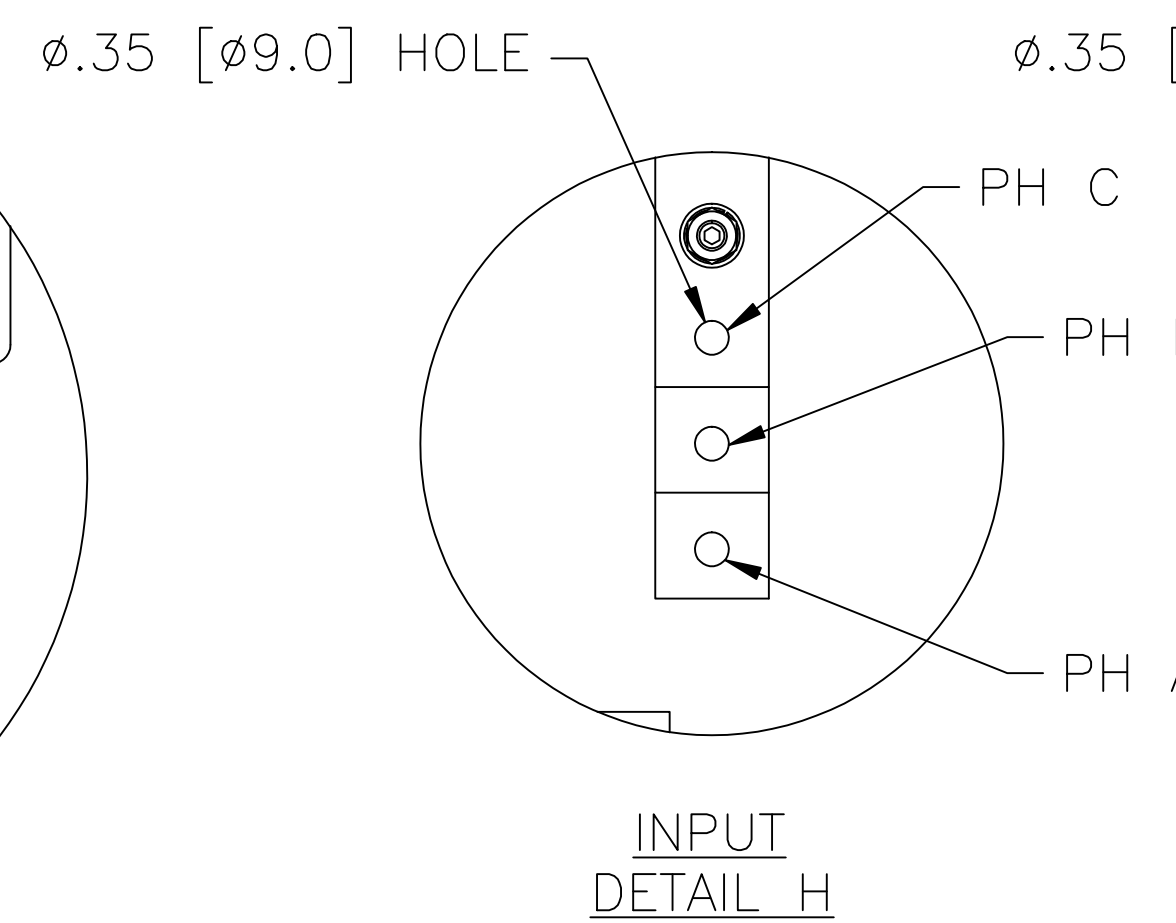

INPUT
DETAIL H

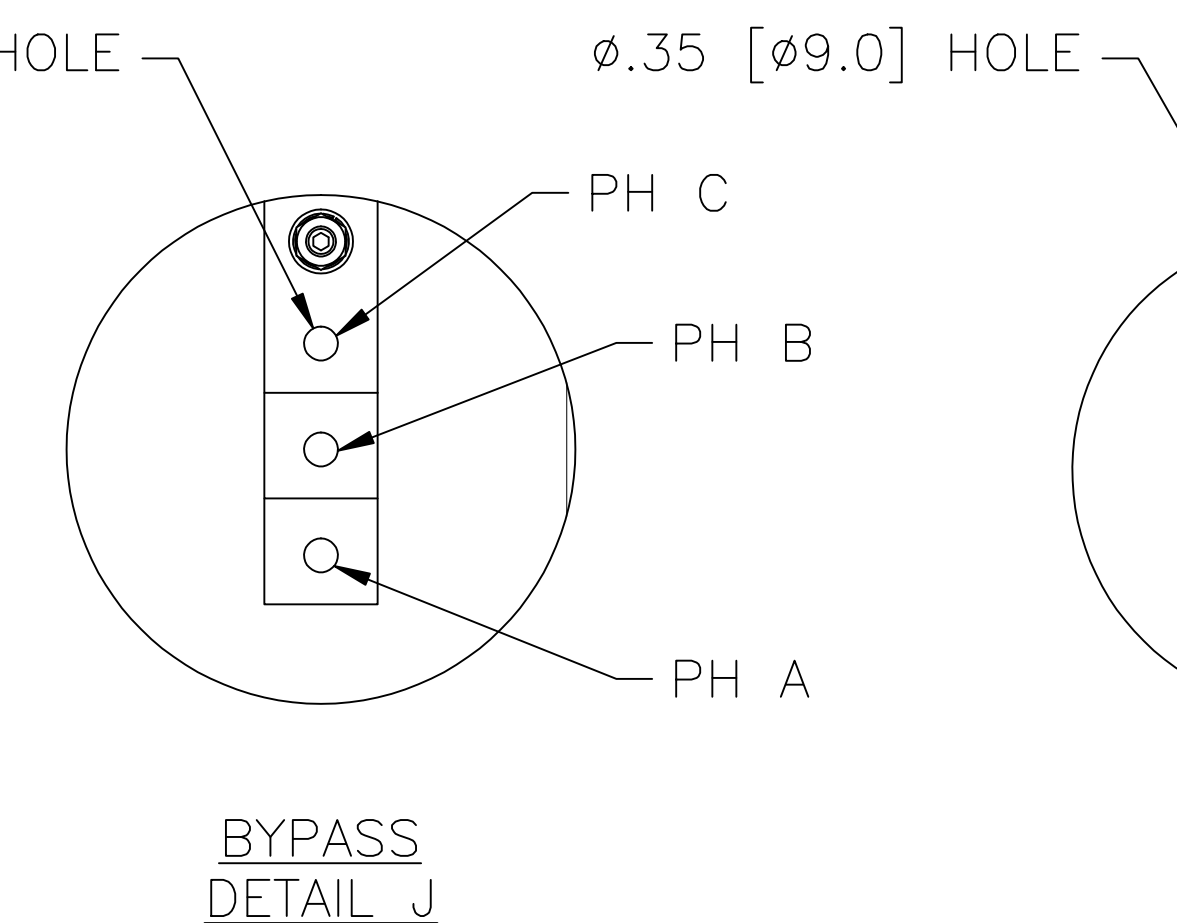

BYPASS
DETAIL J

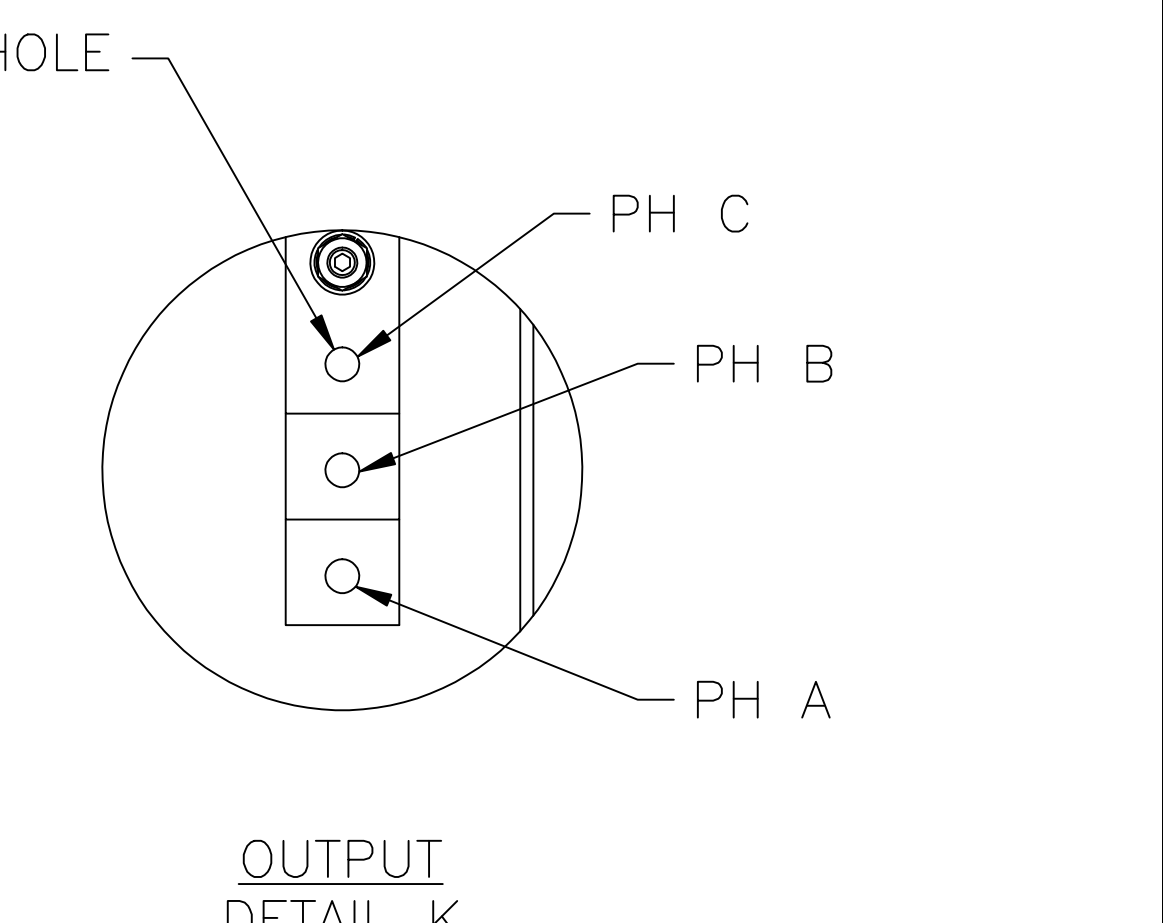

OUTPUT
DETAIL K

UNLESS OTHERWISE SPECIFIED, TOLERANCE IS #		UNITS		TITLE: SPECIFICATION CONTROL DRAWING	
DIMENSIONAL	XX .010 .06	HOLES	.005	INCHES	FIRSTLINE P UPS
ANGLES	1°	DRAFT	1-1/2°	SCALE	DWG.
MATERIAL:		ALL DIMENSIONS APPLY AFTER PLATING		UNINTERRUPTIBLE POWER SUPPLY	
DRAWN BY		DATE	FIRST USED ON	DO NOT SCALE DWG.	
S.A. SMITH		11/11/10			
CHECKER		DATE	WEIGHT APPROX.	CAGE CODE	
SAS		11/11/10		83008	
ENGINEER		DATE	SCALE	SHEET 3 OF 3	
R. BAKER		1/17/11	1/8	D 096-6017	

