

NOTES:

THE REGULATOR COMPRISES A MOTOR DRIVEN VARIABLE AUTOTRANSFORMER, A BUCK-BOOST FIXED RATIO TRANSFORMER AND A MICROPROCESSOR BASED SOLID STATE CONTROL UNIT THAT AUTOMATICALLY POSITIONS THE AUTOTRANSFORMER TO HOLD THE OUTPUT VOLTAGE CONSTANT.

SPECIFICATIONS:

WAVEFORM DISTORTION — — — — — ZERO
 FREQUENCY RANGE — — — — — 47Hz TO 63Hz
 ACCURACY — — — — — ±1.0% #
 INTERNAL IMPEDANCE — — — — — EXTREMELY LOW
 PHASE SHIFT — — — — — NEGLIGIBLE
 EFFICIENCY — — — — — APPROXIMATELY 98%
 TEMPERATURE RANGE — — — — — 0°C (32°F) TO +50°C (122°F)

CONTROLS:

VOLTAGE METER: AN ANALOG 0-150 VAC METER IS PROVIDED TO READ THE OUTPUT VOLTAGE.

SET POINT: THIS POTENTIOMETER CONTROL IS ROTATED CLOCKWISE TO INCREASE THE OUTPUT VOLTAGE SET POINT AND COUNTERCLOCKWISE TO DECREASE THE OUTPUT VOLTAGE SET POINT.

CONTROL CIRCUIT SWITCH: THIS ILLUMINATED PUSHBUTTON SWITCH IS PROVIDED TO INDICATE THAT THE CONTROL UNIT IS OPERATING WHEN ILLUMINATED AND AS A RESET SWITCH FOR THE MICROPROCESSOR.

REGULATION IS ±0.5% FOR +6% THRU -16% OF THE INPUT VOLTAGE RANGE.

* AT NOMINAL OUTPUT VOLTAGE. INPUT VOLTAGE RANGE (+7% TO -17%) SHIFTS PROPORTIONALLY WITH OUTPUT VOLTAGE SETTINGS.

++ INPUT RANGE IN VOLTS DIVIDED BY THE MOTOR DRIVE TRAVEL TIME IN SECONDS.

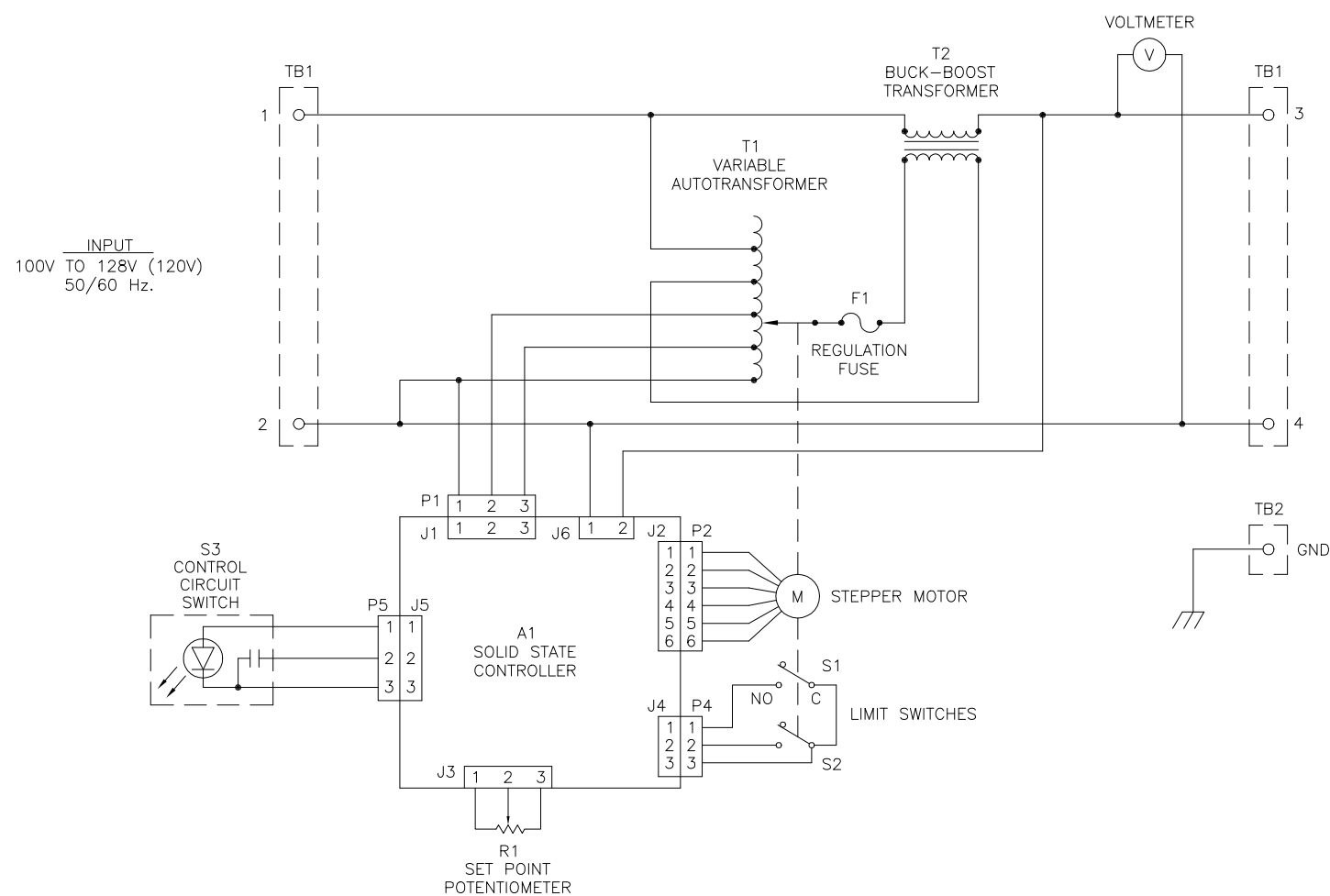

SINGLE PHASE 50/60Hz				
NOMINAL OUTPUT VOLTAGE	INPUT VOLTAGE RANGE*	MAXIMUM OUTPUT AMPERES	RATED OUTPUT (KVA)	CORRECTION RATE (VOLTS/SECOND)++
120	100-128	83.3	10	28

UNLESS OTHERWISE SPECIFIED, TOLERANCE IS #		UNITS		TITLE: SPEC. CONTROL DRAWING			
DECIMALS	Holes	ANGLES	DRAFT	IN [mm]			
.XX	.125	1°	1-1/2°	ALL DIMENSIONS APPLY AFTER PLATING		DRAWN BY S.A. SMITH	
DATE 6/20/96		FIRST USED ON		DO NOT SCALE DWG.		CUSTOMER APPROVAL	
DATE		WEIGHT APPROX.		CODE IDENT. NO. 83008		DATE	
DATE		SCALE .50=1		SHEET 1 OF 1		DWG. NO. 095-1879	