

User's Manual for
The FIRSTLINE UPS
EMERGENCY LIGHTING SYSTEM

8KW, 12KW, AND 16KW



301 Gaddis Boulevard • Dayton, Ohio 45403
U.S. Toll Free 866-261-1191
(937) 253-1191 • Fax: (937) 253-1723
Web site: www.stacoenergy.com

Before Installing the Emergency Lighting Systems:

- Read all safety and installation instructions.
- Make sure that the System is the correct model for your application.
- Verify that the available power source matches the input rating of the UPS. Unless the UPS is equipped with a transformer option, the source should be 120 volts line to neutral, three phase, ABC sequence, with a grounded neutral.

Before starting the UPS:

- Read all safety and operating instructions.
- Verify that the UPS is installed in a clean, temperature controlled area.
- If the UPS is installed at an altitude above 1000 meters, the output load capability must be de-rated by 1% for each 100 meters above 1000 meters.
- Verify that the installation includes an input breaker of the proper rating.
- Verify that the wiring is correct and that all connections are neat and tight.
- Verify that the internal batteries in the UPS have been connected.
- Verify that the Extended Run Time Battery Cabinet is equipped with the optional breaker or that an external breaker has been provided as part of the installation. The battery breaker should be closed before the UPS is started.
- Make sure that single phase loads are fairly evenly distributed across the three output phases. Balanced operation maximizes efficiency and reliability. (Check the individual output phase currents when the UPS is operating)

CONTENTS

Section 1 1
 Introduction..... 1
 FirstLine Emergency Lighting System Part Number Scheme 3
Section 2 4
 Safety Warnings 4
Section 3 6
 UPS Setup..... 6
 Inspecting the Equipment 6
 Clearances 6
 Floor Loading..... 7
 Unloading the Cabinet(s) 8
 Placing the Cabinet..... 10
Section 4 11
 Electrical Installation 11
 Wiring Preparation 11
 Wiring Installation 13
 Wiring Specifications and Diagrams 15
 To begin wiring the Battery Cabinet(s)..... 18
 Removing and Replacing the Front Panel 20
 Check the Internal Battery 20
 Connecting the FirstLine Battery Cabinet to the UPS 22
Section 5 25
 Circuit breaker interface..... 25
Section 6 27
 Communication..... 27
 Customer Interface 27
Section 7 30
 Operation..... 30
 System Normal 30
 On Battery 30
 Abnormal 30
 Display Functions 32
Section 8 33
 Initial Start Up 33
 Normal Operation 33
 Testing the Emergency Lighting System 34
 Manual Transfer to Bypass..... 34
 Manual Transfer to Inverter 34
 External Bypass Arrangement 35
 Automatic Transfer to Bypass..... 35
 Automatic Transfer to Inverter 35
 Over Load..... 35
 Rectifier 36
Section 9 37
 Battery Removal, Installation, and Service 37
 Polarity Verification Procedure 39
 Stopping the Rectifier in the UPS 40
 To transfer to MBS:..... 41
 UPS Maintenance..... 42

Section 10 43
 FirstLine UPS Technical Specifications 43

Figure 1- The FirstLine UPS 8–16 KW 1
Figure 2- The FirstLine Extended Run Time Battery Cabinet 2
Figure 3-UPS on pallet 8
Figure 4-Shipping Bracket 9
Figure 5-Lifting fork area 10
Figure 6-Leveling foot being adjusted down to the floor 10
Figure 7-Bottom View 12
Figure 8-Terminal Blocks 13
Figure 9-Wiring Single Line Diagram 17
Figure 10- Removing the Battery Cabinet Front Panel 18
Figure 11-Bottom View, Battery Cabinet 19
Figure 12-Removing the UPS Front Panel 20
Figure 13-Internal Battery 21
Figure 14-Input/Output Panel 22
Figure 15-UPS Connections 23
Figure 16-Battery Breaker Interface Board Assembly 25
Figure 17-Battery Breaker Connector 26
Figure 18-Communication Options and Control Terminals 27
Figure 19 TB3 28
Figure 20-TB4 28
Figure 21-FirstLine Front Panel Display and Control Module 30
Figure 22-Battery Tray 38
Figure 23-Battery Installation 38

Table 1-Part Numbering System 3
Table 2-Symbols 4
Table 3-Model Floor Loadings 7
Table 4-Input/Output Terminal 13
Table 5-Ground Lugs 13
Table 6-FirstLine UPS 8, 12, 16 KW Current Requirements 14
Table 7 Terminal Block Wiring 16
Table 8-Torque Values for TB1, 2,3,4 29
Table 9-Indicator Status and Description 31
Table 10-Menu Pap for Display Functions 32
Table 11-Technical Specifications 43

SECTION 1

Introduction

The FirstLine UPS Emergency Lighting System is designed to provide power for maintaining critical lighting when utility power is not available. The combination of the UPS (uninterruptible power supply) and external batteries provide rated power for up to 90 minutes of operation during utility power outages. The true online, double conversion, three-phase UPS provides clean, well-regulated, sinusoidal voltage to the lighting loads.

Figure 1 shows the UPS cabinet dimensions. Figure 2 shows the Battery Cabinet dimensions. The 480 volt, 16 kW model uses two battery cabinets; all other systems consist of the UPS and one battery cabinet.

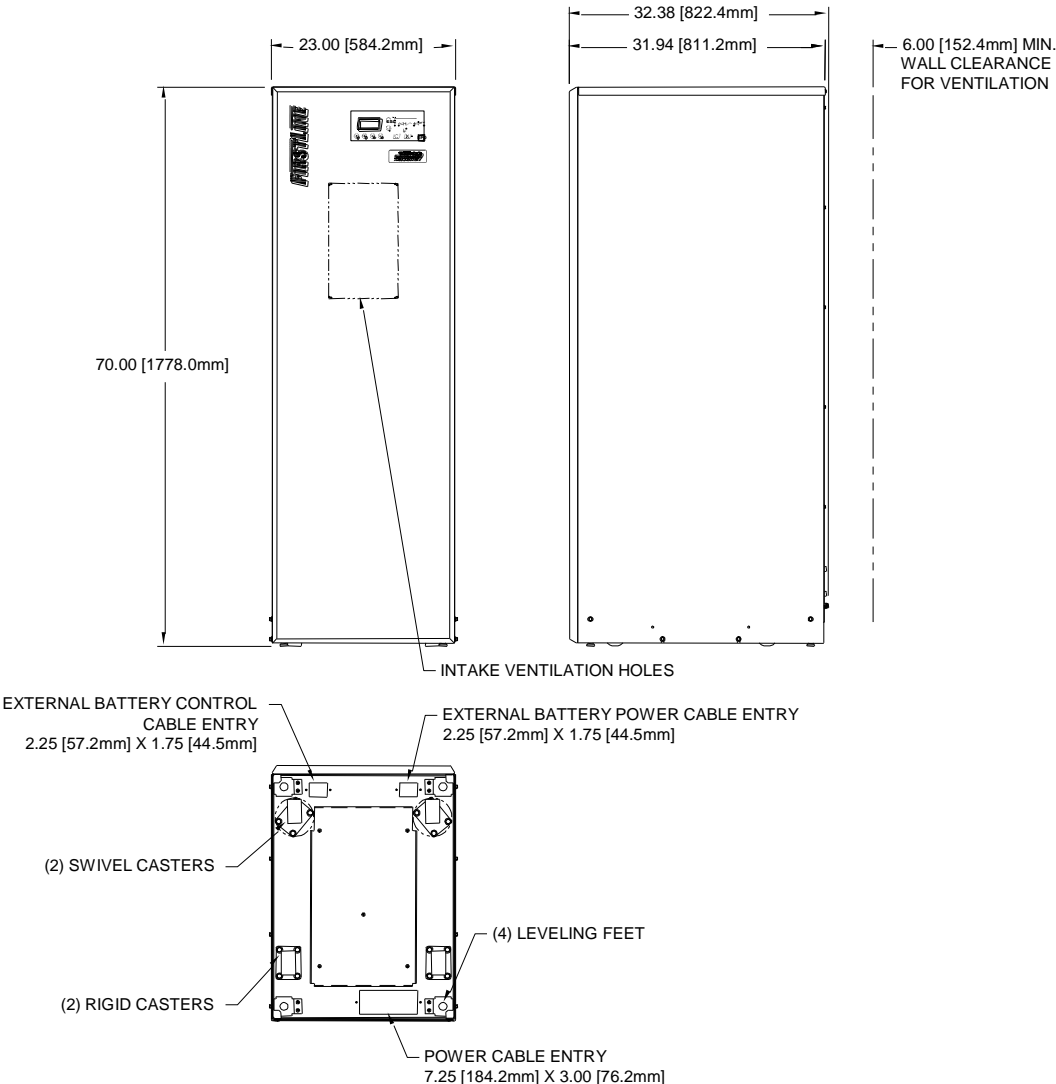

Figure 1- The FirstLine UPS 8-16 KW

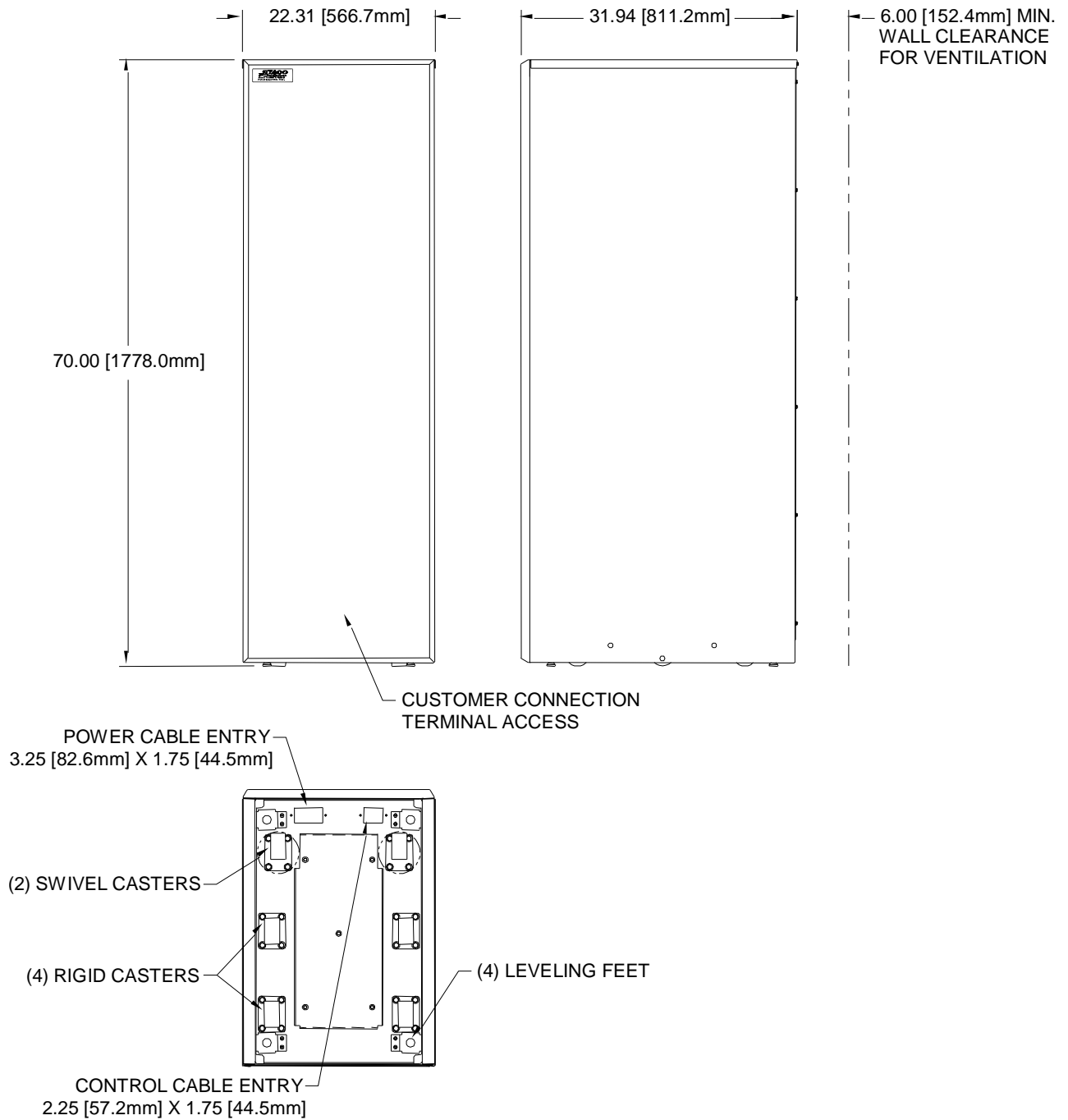

Figure 2- The FirstLine Extended Run Time Battery Cabinet

FirstLine Emergency Lighting System Part Number Scheme

Table 1-Part Numbering System

System Part Number	Rating	Vin	Vout	System Consists Of		
				UPS Part Number	Battery Cabinet Part Number	Second Battery Cabinet Part Number
FLU924-8-20-N	8 kW	208/120Y	208/120Y	FLU-10T-20-1	FLU-BAT-20-2-N	(not required)
FLU924-8-20-B	8 kW	208/120Y	208/120Y	FLU-10T-20-1	FLU-BAT-20-2-B	(not required)
FLU924-8-20-N-I	8 kW	208 Delta	208/120Y	FLU-10T-20-1-I	FLU-BAT-20-2-N	(not required)
FLU924-8-20-B-I	8 kW	208 Delta	208/120Y	FLU-10T-20-1-I	FLU-BAT-20-2-B	(not required)
FLU924-8-42-N	8 kW	480/277Y	208/120Y	FLU-10T-42-1	FLU-BAT-20-2-N	(not required)
FLU924-8-42-B	8 kW	480/277Y	208/120Y	FLU-10T-42-1	FLU-BAT-20-2-B	(not required)
FLU924-8-42-N-I	8 kW	480 Delta	208/120Y	FLU-10T-42-1-I	FLU-BAT-20-2-N	(not required)
FLU924-8-42-B-I	8 kW	480 Delta	208/120Y	FLU-10T-42-1-I	FLU-BAT-20-2-B	(not required)
FLU924-8-44-N	8 kW	480/277Y	480/277Y	FLU-10T-44-1	FLU-BAT-20-2-N	(not required)
FLU924-8-44-B	8 kW	480/277Y	480/277Y	FLU-10T-44-1	FLU-BAT-20-2-B	(not required)
FLU924-8-44-N-I	8 kW	480 Delta	480/277Y	FLU-10T-44-1-I	FLU-BAT-20-2-N	(not required)
FLU924-8-44-B-I	8 kW	480 Delta	480/277Y	FLU-10T-44-1-I	FLU-BAT-20-2-B	(not required)
FLU924-12-20-N	12 kW	208/120Y	208/120Y	FLU-15T-20-1	FLU-BAT-20-3-N	(not required)
FLU924-12-20-B	12 kW	208/120Y	208/120Y	FLU-15T-20-1	FLU-BAT-20-3-B	(not required)
FLU924-12-20-N-I	12 kW	208 Delta	208/120Y	FLU-15T-20-1-I	FLU-BAT-20-3-N	(not required)
FLU924-12-20-B-I	12 kW	208 Delta	208/120Y	FLU-15T-20-1-I	FLU-BAT-20-3-B	(not required)
FLU924-12-42-N	12 kW	480/277Y	208/120Y	FLU-15T-42-1	FLU-BAT-20-3-N	(not required)
FLU924-12-42-B	12 kW	480/277Y	208/120Y	FLU-15T-42-1	FLU-BAT-20-3-B	(not required)
FLU924-12-42-N-I	12 kW	480 Delta	208/120Y	FLU-15T-42-1-I	FLU-BAT-20-3-N	(not required)
FLU924-12-42-B-I	12 kW	480 Delta	208/120Y	FLU-15T-42-1-I	FLU-BAT-20-3-B	(not required)
FLU924-12-44-N	12 kW	480/277Y	480/277Y	FLU-15T-44-1	FLU-BAT-20-3-N	(not required)
FLU924-12-44-B	12 kW	480/277Y	480/277Y	FLU-15T-44-1	FLU-BAT-20-3-B	(not required)
FLU924-12-44-N-I	12 kW	480 Delta	480/277Y	FLU-15T-44-1-I	FLU-BAT-20-3-N	(not required)
FLU924-12-44-B-I	12 kW	480 Delta	480/277Y	FLU-15T-44-1-I	FLU-BAT-20-3-B	(not required)
FLU924-16-20-N	16 kW	208/120Y	208/120Y	FLU-20T-20-2	FLU-BAT-20-3-N	(not required)
FLU924-16-20-B	16 kW	208/120Y	208/120Y	FLU-20T-20-2	FLU-BAT-20-3-B	(not required)
FLU924-16-20-N-I	16 kW	208 Delta	208/120Y	FLU-20T-20-1-I	FLU-BAT-20-2-N	FLU-BAT-20-2-N
FLU924-16-20-B-I	16 kW	208 Delta	208/120Y	FLU-20T-20-1-I	FLU-BAT-20-2-B	FLU-BAT-20-2-B
FLU924-16-42-N	16 kW	480/277Y	208/120Y	FLU-20T-42-1	FLU-BAT-20-2-N	FLU-BAT-20-2-N
FLU924-16-42-B	16 kW	480/277Y	208/120Y	FLU-20T-42-1	FLU-BAT-20-2-B	FLU-BAT-20-2-B
FLU924-16-42-N-I	16 kW	480 Delta	208/120Y	FLU-20T-42-1-I	FLU-BAT-20-2-N	FLU-BAT-20-2-N
FLU924-16-42-B-I	16 kW	480 Delta	208/120Y	FLU-20T-42-1-I	FLU-BAT-20-2-B	FLU-BAT-20-2-B
FLU924-16-44-N	16 kW	480/277Y	480/277Y	FLU-20T-44-1	FLU-BAT-20-2-N	FLU-BAT-20-2-N
FLU924-16-44-B	16 kW	480/277Y	480/277Y	FLU-20T-44-1	FLU-BAT-20-2-B	FLU-BAT-20-2-B
FLU924-16-44-N-I	16 kW	480 Delta	480/277Y	FLU-20T-44-1-I	FLU-BAT-20-2-N	FLU-BAT-20-2-N
FLU924-16-44-B-I	16 kW	480 Delta	480/277Y	FLU-20T-44-1-I	FLU-BAT-20-2-B	FLU-BAT-20-2-B

- B signifies that the battery cabinets are equipped with a disconnect breaker.
- N signifies that the battery cabinets are not equipped with a disconnect breaker and the breaker must be provided externally as part of the installation.
- I signifies that the UPS has an input isolation transformer and does not require an input neutral.

SECTION 2

Safety Warnings







**IMPORTANT SAFETY INSTRUCTIONS
SAVE THESE INSTRUCTIONS**

This manual contains important instructions that you should follow during installation and maintenance of the UPS and batteries. Please read all instructions before operating the equipment and save this manual for future reference.

READ AND FOLLOW ALL SAFETY INSTRUCTIONS

- a. Do not use outdoors.
- b. Do not route wiring across or near hot surfaces.
- c. Do not install near gas or electric heaters.
- d. Use caution when servicing batteries. Battery acid can cause burns to skin and eyes. If acid is spilled on skin or in eyes, flush acid with fresh water and contact a physician immediately.
- e. Equipment should be installed where it will not readily be subjected to tampering by unauthorized personnel.
- f. The use of accessory equipment not recommended by the manufacturer may cause an unsafe condition.
- g. Do not use this equipment for other than intended use.

Table 2-Symbols

	Danger / Risk of Electric Shock
	Caution
	Risk of Explosion
	Note
	Ground Connection
	Electrostatic Sensitive Device

DANGER



This UPS contains LETHAL VOLTAGES. All repairs and service should be performed by AUTHORIZED SERVICE PERSONNEL ONLY. There are NO USER SERVICEABLE PARTS inside the UPS.

WARNING



- This UPS contains its own energy source (batteries). The UPS output may carry live voltage even when the UPS is not connected to an AC supply.
- To reduce the risk of fire or electric shock, install this UPS in a temperature and humidity controlled, indoor environment, free of conductive contaminants. Do not operate near water or excessive humidity (95% maximum).
- Input and output over-current protection and disconnect switches must be provided by others.

CAUTION



Batteries can present a risk of electrical shock or burn from high short circuit current. Observe proper precautions. Servicing should be performed by qualified service personnel knowledgeable of batteries and required precautions. Keep unauthorized personnel away from batteries.



Risk of explosion if batteries are replaced by an incorrect type. Replace with same type and rating only.

Proper disposal of batteries is required. Refer to your local codes for disposal requirements.

Never dispose of batteries in a fire. Batteries may explode when exposed to flame.

SECTION 3

UPS Setup

This section describes:

- Equipment inspection
- Floor loading and clearances
- Removing and replacing the cabinet panels
- Unloading the cabinet(s)

Inspecting the Equipment

If any equipment has been damaged during shipment, keep the shipping and packing materials for the carrier or place of purchase and file a claim for shipping damage. If you discover damage after acceptance, file a claim for concealed damage.

To file a claim for shipping damage or concealed damage: 1) File with the carrier within 15 days of receipt of the equipment, 2) Send a copy of the damage claim within 15 days to your service representative.

Clearances

The following clearances are recommended for the FirstLine UPS.

From Front of Cabinet	36" (91.4 cm) working space
From Back of Cabinet	6" (15.2 cm)
From Side of Cabinet	Minimum 24" (61 cm)

The following clearances are recommended for the FirstLine Extended Run Time Battery Cabinet.

From Front of Cabinet	36" (91.4 cm) working space
From Back of Cabinet	6" (15.2 cm)
From Side of Cabinet to UPS	Minimum 24" (61 cm)

Floor Loading

When planning the installation, consider the Emergency Lighting System’s weight for floor loading. The strength of the installation surface must be adequate for point and distributed loading. The approximate weights are shown in the following table.

Table 3-Model Floor Loadings

System Part Number	Rating	Vin	Vout	UPS Cabinet				Battery Cabinet(s)			
				Maximum Weight		Point Loading		Maximum Weight		Point Loading	
				Lbs	kg	Lbs/in ²	kg/cm ²	Lbs	kg	Lbs/in ²	kg/cm ²
FLU924-8-20-N	8 kW	208/120Y	208/120Y	1024	464	326	23	1385	628	441	31
FLU924-8-20-B	8 kW	208/120Y	208/120Y	1024	464	326	23	1385	628	441	31
FLU924-8-20-N-I	8 kW	208/120Y	208/120Y	1314	596	418	29	1385	628	441	31
FLU924-8-20-B-I	8 kW	208/120Y	208/120Y	1314	596	418	29	1385	628	441	31
FLU924-8-42-N	8 kW	480/277Y	208/120Y	1200	544	382	27	1385	628	441	31
FLU924-8-42-B	8 kW	480/277Y	208/120Y	1200	544	382	27	1385	628	441	31
FLU924-8-42-N-I	8 kW	480/277Y	208/120Y	1335	606	425	30	1385	628	441	31
FLU924-8-42-B-I	8 kW	480/277Y	208/120Y	1335	606	425	30	1385	628	441	31
FLU924-8-44-N	8 kW	480/277Y	480/277Y	1485	674	473	33	1385	628	441	31
FLU924-8-44-B	8 kW	480/277Y	480/277Y	1485	674	473	33	1385	628	441	31
FLU924-8-44-N-I	8 kW	480/277Y	480/277Y	1620	735	516	36	1385	628	441	31
FLU924-8-44-B-I	8 kW	480/277Y	480/277Y	1620	735	516	36	1385	628	441	31
FLU924-12-20-N	12 kW	208/120Y	208/120Y	1024	464	326	23	1919	870	611	43
FLU924-12-20-B	12 kW	208/120Y	208/120Y	1024	464	326	23	1919	870	611	43
FLU924-12-20-N-I	12 kW	208/120Y	208/120Y	1314	596	418	30	1919	870	611	43
FLU924-12-20-B-I	12 kW	208/120Y	208/120Y	1314	596	418	30	1919	870	611	43
FLU924-12-42-N	12 kW	480/277Y	208/120Y	1200	544	382	27	1919	870	611	43
FLU924-12-42-B	12 kW	480/277Y	208/120Y	1200	544	382	27	1919	870	611	43
FLU924-12-42-N-I	12 kW	480/277Y	208/120Y	1335	606	425	30	1919	870	611	43
FLU924-12-42-B-I	12 kW	480/277Y	208/120Y	1335	606	425	30	1919	870	611	43
FLU924-12-44-N	12 kW	480/277Y	480/277Y	1485	674	473	33	1919	870	611	43
FLU924-12-44-B	12 kW	480/277Y	480/277Y	1485	674	473	33	1919	870	611	43
FLU924-12-44-N-I	12 kW	480/277Y	480/277Y	1620	735	516	36	1919	870	611	43
FLU924-12-44-B-I	12 kW	480/277Y	480/277Y	1620	735	516	36	1919	870	611	43
FLU924-16-20-N	16 kW	208/120Y	208/120Y	1558	707	496	35	1919	870	611	43
FLU924-16-20-B	16 kW	208/120Y	208/120Y	1558	707	496	35	1919	870	611	43
FLU924-16-20-N-I	16 kW	208/120Y	208/120Y	1314	596	418	30	1385	628	441	31
FLU924-16-20-B-I	16 kW	208/120Y	208/120Y	1314	596	418	30	1385	628	441	31
FLU924-16-42-N	16 kW	480/277Y	208/120Y	1200	544	382	27	1385	628	441	31
FLU924-16-42-B	16 kW	480/277Y	208/120Y	1200	544	382	27	1385	628	441	31
FLU924-16-42-N-I	16 kW	480/277Y	208/120Y	1335	606	425	30	1385	628	441	31
FLU924-16-42-B-I	16 kW	480/277Y	208/120Y	1335	606	425	30	1385	628	441	31
FLU924-16-44-N	16 kW	480/277Y	480/277Y	1485	674	473	33	1385	628	441	31
FLU924-16-44-B	16 kW	480/277Y	480/277Y	1485	674	473	33	1385	628	441	31
FLU924-16-44-N-I	16 kW	480/277Y	480/277Y	1620	735	516	36	1385	628	441	31
FLU924-16-44-B-I	16 kW	480/277Y	480/277Y	1620	735	516	36	1385	628	441	31

Please note that there are two Battery Cabinets for all 16 kW Systems except the FLU924-16-20-N and the FLU924-16-20-B. All other Systems use just one Battery Cabinet. Refer to Table 1.

Unloading the Cabinet(s)

The following tools are required for unloading the cabinet(s):

- Wrenches for 1/4" bolts and 1/2" nut
- Forklift

CAUTION



The UPS and Battery cabinets are heavy (see Table 3). Unloading the cabinets requires at least two people to safely remove the cabinets from the pallet.

To remove the UPS or Battery cabinets from the ship pallet:

1. Remove all banding, wrapping, and foam protectors.
2. Loosen the six 1/2" nuts and washers securing the shipping brackets to the pallet (see Figures 3 and 4).
3. Remove and discard the four 1/4" bolts and washers securing the shipping brackets to the cabinet side panels, also remove the four 1/4" bolts and washers the brackets surrounds but does not touch. Save these as they must be reinstalled later. Pull the brackets away from the cabinet..

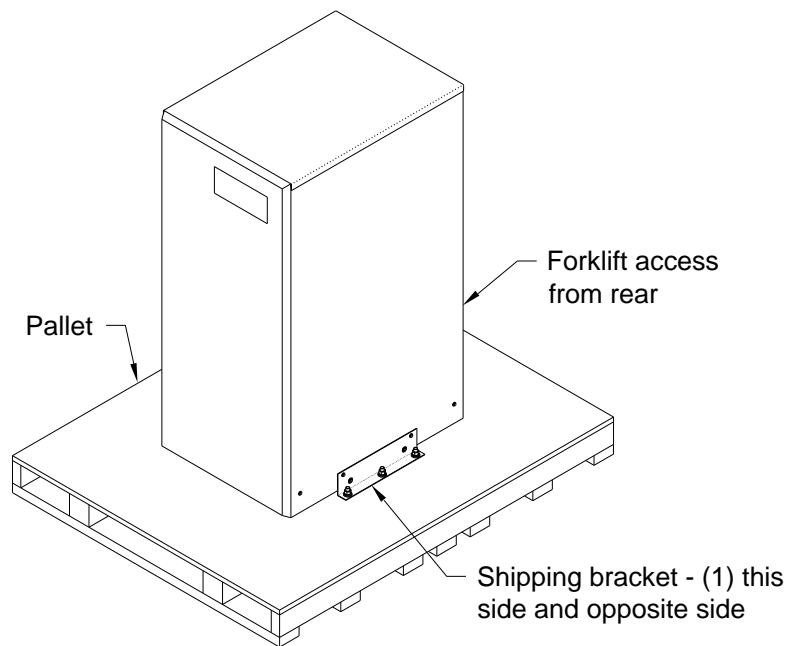

Figure 3-UPS on pallet

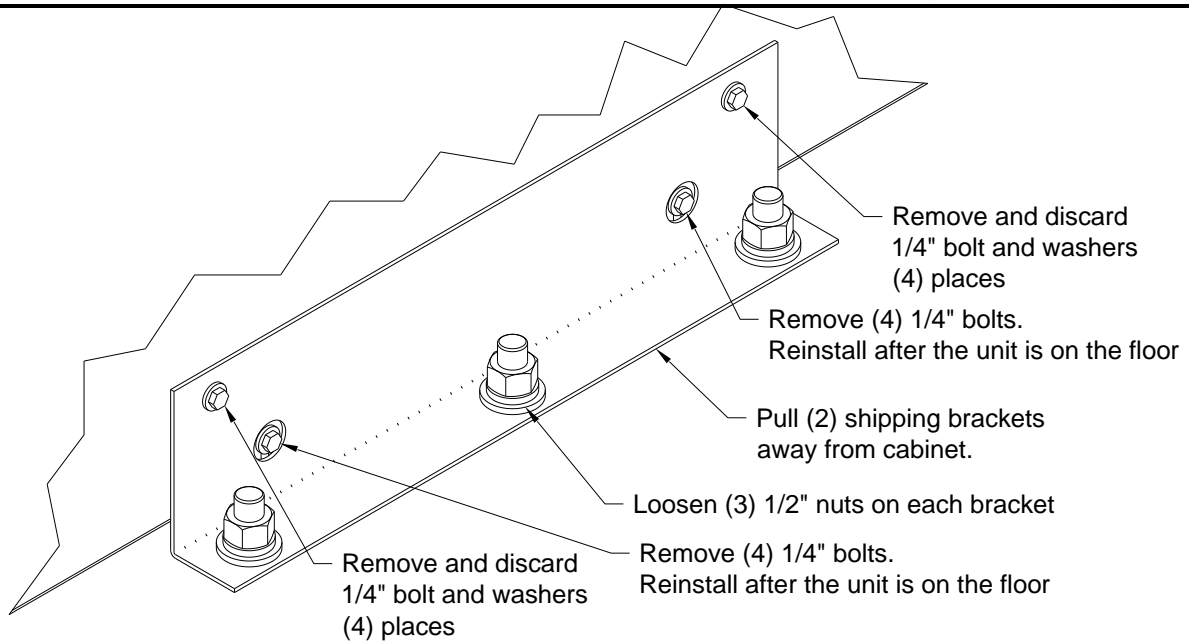

Figure 4-Shipping Bracket

4. Remove the front cover (see Figure 12) before inserting the lifting forks.
5. Ensure that the four (4) leveling feet are raised so that they will not touch the floor when the cabinet is placed on the floor.
6. Lift the cabinet with a forklift from the rear of the unit, one to two inches (1"-2" [2.5-5cm]) above the pallet (see figure 5).
7. Slide the pallet completely away from the raised cabinet.
8. Slowly lower the cabinet to the floor.
9. Reinstall the front cover and (4) 1/4" bolts and washers (see figure 4).
10. Roll the cabinet to the desired location.
11. Do not move the cabinet to another location by forklift as the cabinets are heavy and may fall.



DO NOT ALLOW THE FORKLIFT TO MOVE WHILE THE CABINET IS RAISED, ONLY MOVE THE CABINET VERTICALLY TO REMOVE THE PALLET FROM UNDER THE CABINET

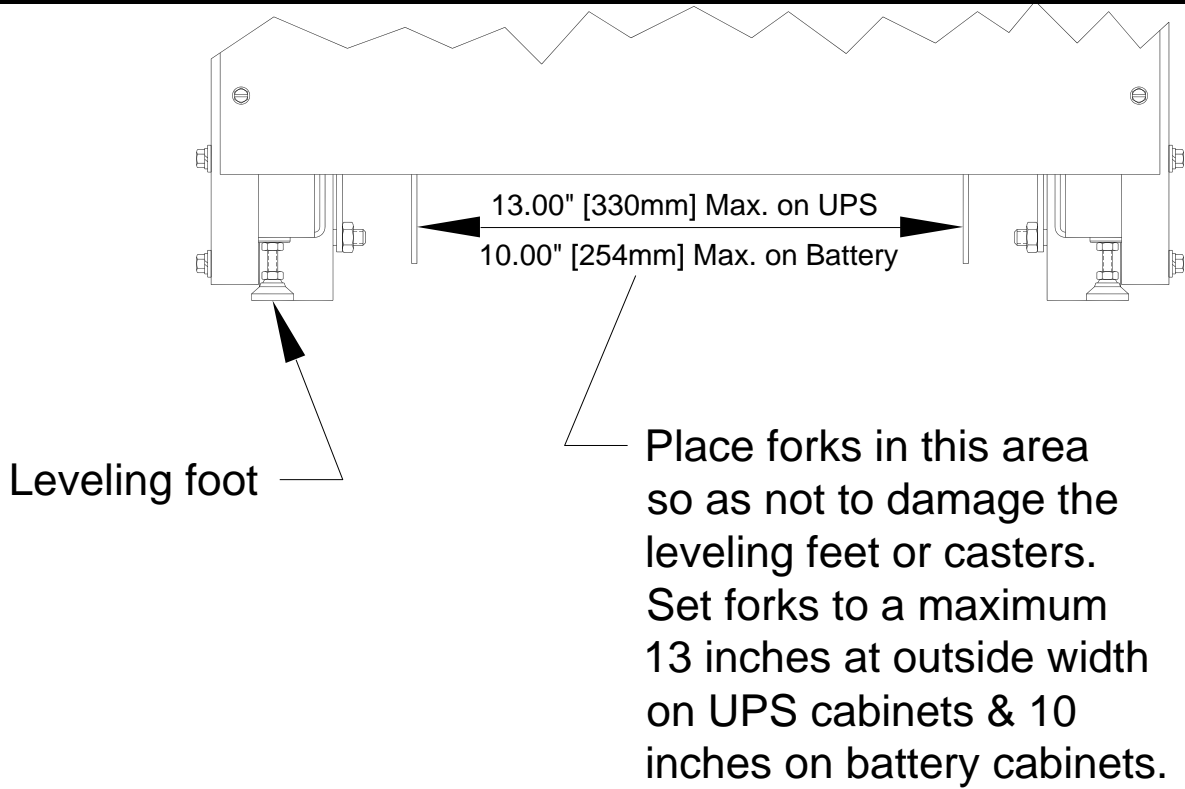

Figure 5-Lifting fork area

Placing the Cabinet

Once the cabinet has been rolled into position, remove the front panel to access the front leveling feet by pulling the panel outward at the bottom of the unit until it unsnaps and then lift up and off the cabinet (see figure 9). Adjust the leveling feet as shown in figure 6.

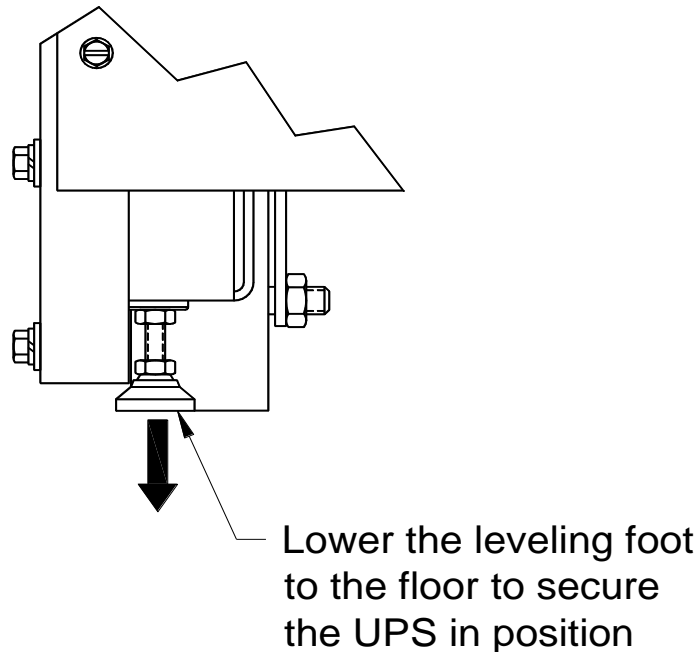

Figure 6-Leveling foot being adjusted down to the floor

SECTION 4

Electrical Installation

The FirstLine has the following power connections:

- 3-phase (L1, L2, and L3), neutral, and ground connection for rectifier/bypass input
- 3-phase (L1, L2, and L3), neutral, and ground connection for load output

The input neutral connection is not used when the UPS is equipped with the optional isolation transformer. If the system is equipped with an isolation transformer, the system part number will be FLU924-XX-YY-Z-I, where XX is 16, 12, or 8; YY is 20, 42, or 44; and Z is N or B. That is, the "-I" at the end designates the presence of an input isolation transformer.

The nominal input/output voltages are:

- 120/208 VAC
- 480V, 60 Hz input is available when using an input transformer.
- 480/480 Vac is available when using an input and output transformer.

Input and output overcurrent protection and disconnect switch must be provided by others.

WARNING



Only qualified service personnel (such as a licensed electrician) should perform the UPS installation and initial startup. Risk of electrical shock.

Wiring Preparation

To begin wiring the UPS:

1. Verify that the electrical connections to the installation site have been properly installed.
2. A wall-mounted, user-supplied, readily-accessible disconnection device must be incorporated in the input wiring.

Compare the circuit breaker ratings to the ones in Table 6 on page 14.

3. Switch off utility power to the distribution point where the UPS will be connected. Be absolutely sure there is no power.
4. Determine your equipment's grounding requirements according to your local electrical code.
5. Remove the UPS rear panel.
6. Conduit landing plates are located at the rear bottom of the base to accommodate bottom wire entry to the cabinet (see Figure 7).

Remove plate and drill or punch hole to fit conduit bushing with Greenlee punch or similar device. Make certain that the bushing will be clear in the opening in the base. Mount bushing to plate and tighten to manufacturer's recommendations. Replace the plate and mount conduit.

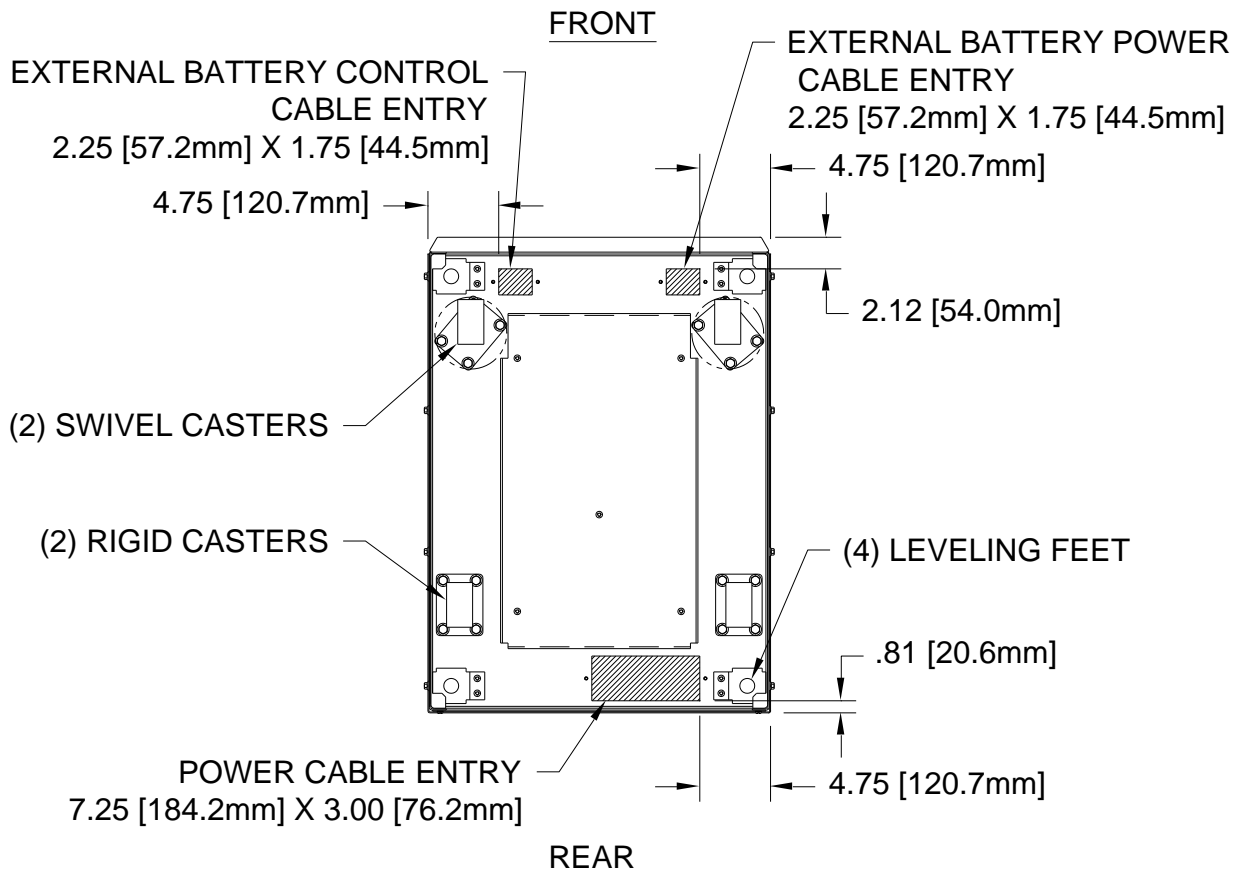

Figure 7-Bottom View

Wiring Installation

1. Unscrew and remove the rear panel.
2. Connect the input wires to the proper terminals shown in Figure 8. Insure proper phase rotation.
3. Connect the output wires to the proper terminals shown in Figure 8.
4. Replace the rear panel.

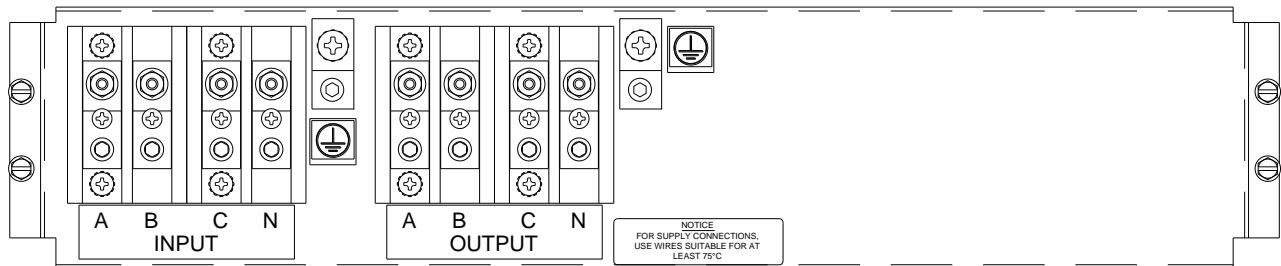

Figure 8-Terminal Blocks

Table 4-Input/Output Terminal

INPUT/OUTPUT TERMINAL TIGHTENING TORQUE	
#2/0 - #6 AWG	120 inch-pounds
#8 - #12 AWG	50 inch-pounds

Table 5-Ground Lugs

GROUND LUGS TIGHTENING TORQUE	
#10 AWG	35 inch-pounds
#8 AWG	40 inch-pounds
#4 - #6 AWG	45 inch-pounds
#1/0 - #2 AWG	50 inch-pounds

Table 6-FirstLine UPS 8, 12, 16 KW Current Requirements

UPS Rating	Input Voltage	Max. Input Current (A) Allowed for Specified Branch Protector	Maximum Allowable Branch Circuit Protection (A)
8 KW	208 V	32	40
8 KW	480 V	14	20
12 KW	208 V	47	60
12 KW	480 V	21	30
16 KW	208 V	63	80
16 KW	480 V	28	35

UPS Rating	Output Voltage	Rated Max. Output Current (A)	Maximum Allowable Circuit Protection (A)
8 KW	208 V	22	(note 1)
8 KW	480 V	10	35
12 KW	208 V	33	(note 1)
12 KW	480 V	15	35
16 KW	208 V	44	(note 1)
16 KW	480 V	19	

Note 1: Output circuit protection requirement determined by distribution circuit.

Wiring Specifications and Diagrams



Note: Unless the system is a "-I" model with an input isolation transformer, the input neutral must be wired for proper operation or the UPS will not start. The input neutral must be grounded at the source. If an input isolation transformer is present, the input neutral is not used and no input neutral wire needs to be provided. The neutral of the isolation transformer is bonded to ground at the UPS. The UPS chassis must be grounded to the source via a grounding conductor per Table 7.

Note: Do not over-tighten the screws; be sure to use the specified tightening torque values shown in Table 4, Table 5, and Table 8.

- 8KW, 208V: **CAUTION** to reduce the risk of fire, connect only to a circuit provided with 40 amperes maximum branch circuit protection in accordance with the National Electrical Code, ANSI/NFPA 70.
- 8 KW, 480V: **CAUTION** to reduce the risk of fire, connect only to a circuit provided with 20 amperes maximum branch circuit protection in accordance with the National Electrical Code, ANSI/NFPA 70.
- 12 KW, 208V: **CAUTION** to reduce the risk of fire, connect only to a circuit provided with 60 amperes maximum branch circuit protection in accordance with the National Electrical Code, ANSI/NFPA 70.
- 12 KW, 480V **CAUTION** to reduce the risk of fire, connect only to a circuit provided with 30 amperes maximum branch circuit protection in accordance with the National Electrical Code, ANSI/NFPA 70.
- 16 KW, 208V **CAUTION** to reduce the risk of fire, connect only to a circuit provided with 80 amperes maximum branch circuit protection in accordance with the National Electrical Code, ANSI/NFPA 70.
- 16 KW, 480V: **CAUTION** to reduce the risk of fire, connect only to a circuit provided with 35 amperes maximum branch circuit protection in accordance with the National Electrical Code, ANSI/NFPA 70.

Table 7 Terminal Block Wiring

UPS Rating	Voltage	Input Transformer Type	Phase Conductor Min/Max	Neutral Conductor Min/Max	Neutral Conductor with non-linear loads Min/Max	Ground Wire Min/Max
10kva	208/120	NA	#8/2-0	#8/2-0	#6/2-0	#8/1-0
	208	isolation	#8/2-0	(none)	(none)	#8/1-0
	480/277	auto	#10/2-0	#10/2-0	#8/2-0	#8/1-0
	480	isolation	#10/2-0	(none)	(none)	#8/1-0
15kva	208/120	NA	#6/2-0	#6/2-0	#4/2-0	#8/1-0
	208	isolation	#6/2-0	(none)	(none)	#8/1-0
	480/277	auto	#8/2-0	#8/2-0	#6/2-0	#8/1-0
	480	isolation	#8/2-0	(none)	(none)	#8/1-0
20kva	208/120	NA	#4/2-0	#4/2-0	#2/2-0	#6/1-0
	208	isolation	#4/2-0	(none)	(none)	#6/1-0
	480/277	auto	#8/2-0	#8/2-0	#6/2-0	#6/1-0
	480	isolation	#8/2-0	(none)	(none)	#6/1-0
OUTPUT -Minimum wire size required to support rated load. Smaller wire may be used if rated load current is not needed and the appropriate circuit protection is applied.						
UPS Rating	Voltage	Output Transformer Type	Phase Conductor	Neutral Conductor	Neutral Conductor with non-linear loads	Ground Wire
10 kVA	208/120	NA	#10	#10	#8	#8/1-0
	480/277	auto	#12	#12	#10	#8/1-0
15 kVA	208/120	NA	#8	#8	#6	#8/1-0
	480/277	auto	#10	#10	#8	#8/1-0
20 kVA	208/120	NA	#6	#6	#4	#6/1-0
	480/277	auto	#10	#10	#8	#6/1-0

Note: No output circuit protection is required if the output conductor sizes are at least as large as the input conductors, unless the UPS is equipped with an input isolation transformer. If the UPS is equipped with an input isolation transformer, the UPS is considered a separately derived source and circuit protection for the output conductors must be provided.

Use at least 75°C-rated copper wire. Minimum wire size is based on 120/208 full load ratings applied to NEC Code Table 310-16. Code may require a large AWG size than shown in this table because of temperature, number of conductors in the conduit, or long service runs. Follow local requirements.

Per NEC article 300-20(2), all three-phase conductors must be run in the same conduit. Neutral and ground must be run in the same conduit as the phase conductors.

Conduit to be sized to accommodate one neutral conductor the same size as the phase conductor and one ground conductor. If two neutral conductors or an oversized neutral conductor are to be installed, check the size of the conduit needed to accommodate the extra wire or size and use that conduit size in place of the conduit size listed. Conduit sizes can be chosen from NEC Table C1, type letters RHH, RHW, RHW-2, TW, THW, THHW, THW-2.

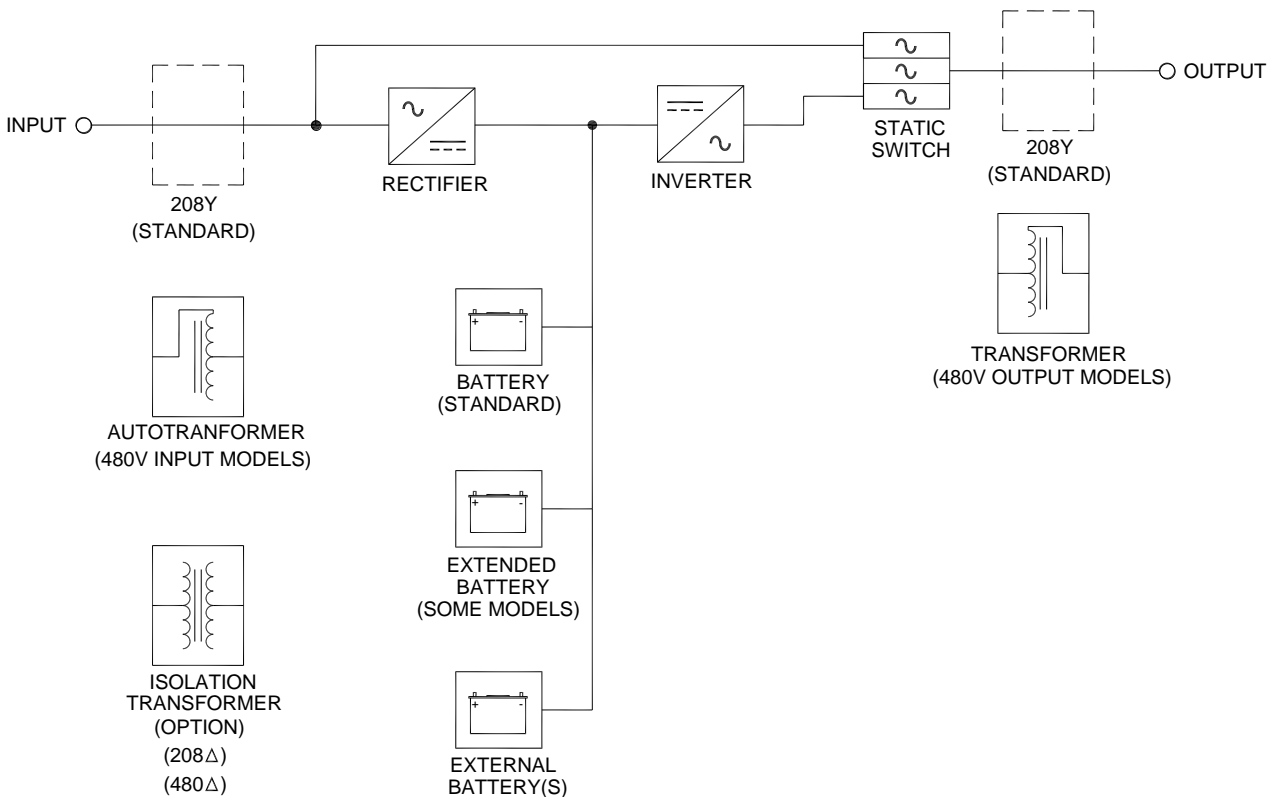

Figure 9-Wiring Single Line Diagram

To begin wiring the Battery Cabinet(s)

1. Switch off utility power to the distribution point where the UPS is connected. Be absolutely sure there is no power.
2. Removing and replacing the front panel:
 - Pull the top of the panel outward until the ball studs unsnap.
 - Lift the panel up and off the cabinet.

To replace the panel:

- Lower the shoulder screws at the bottom of the panel into the keyhole slots on the cabinet.
- Press the panel inward until the ball studs snap into place.

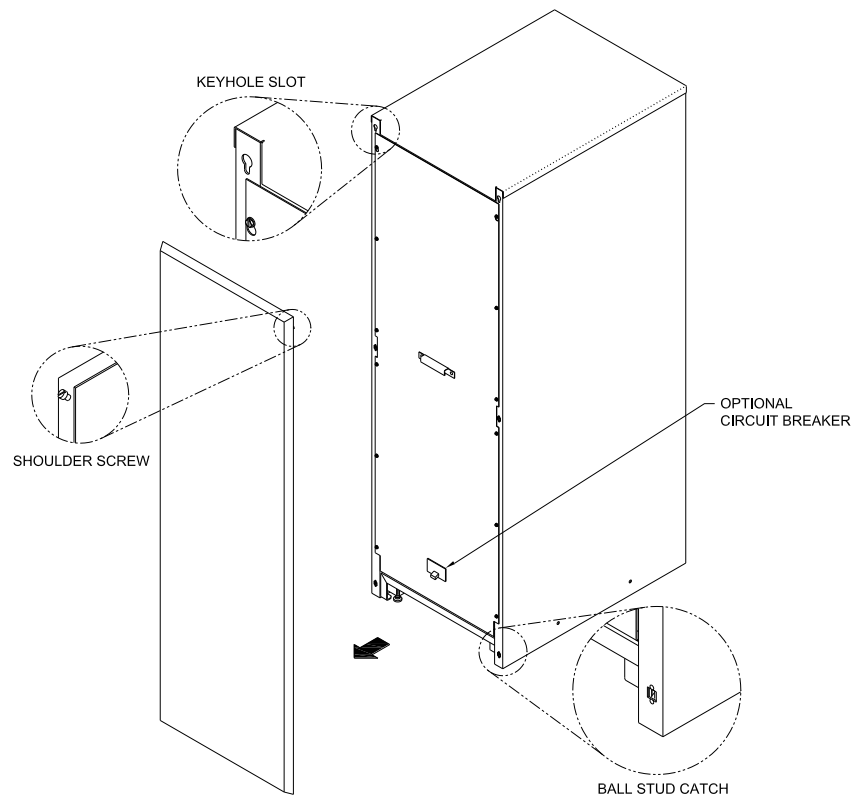

Figure 10- Removing the Battery Cabinet Front Panel

3. If the optional circuit breaker is included, switch it to the “Off” position.
4. Remove the inner front cover by removing the (12) twelve screws mounting it to the enclosure.

5. Conduit landing plates are located at the front bottom of the base to accommodate bottom wire entry to the cabinet (see figure 10).

Remove plates and drill or punch hole to fit conduit bushing with Greenlee punch or similar device. Make certain that the bushing will be clear in the opening in the base. Mount bushing to plate and tighten to manufacturer's recommendations. Replace the plates and mount conduit.

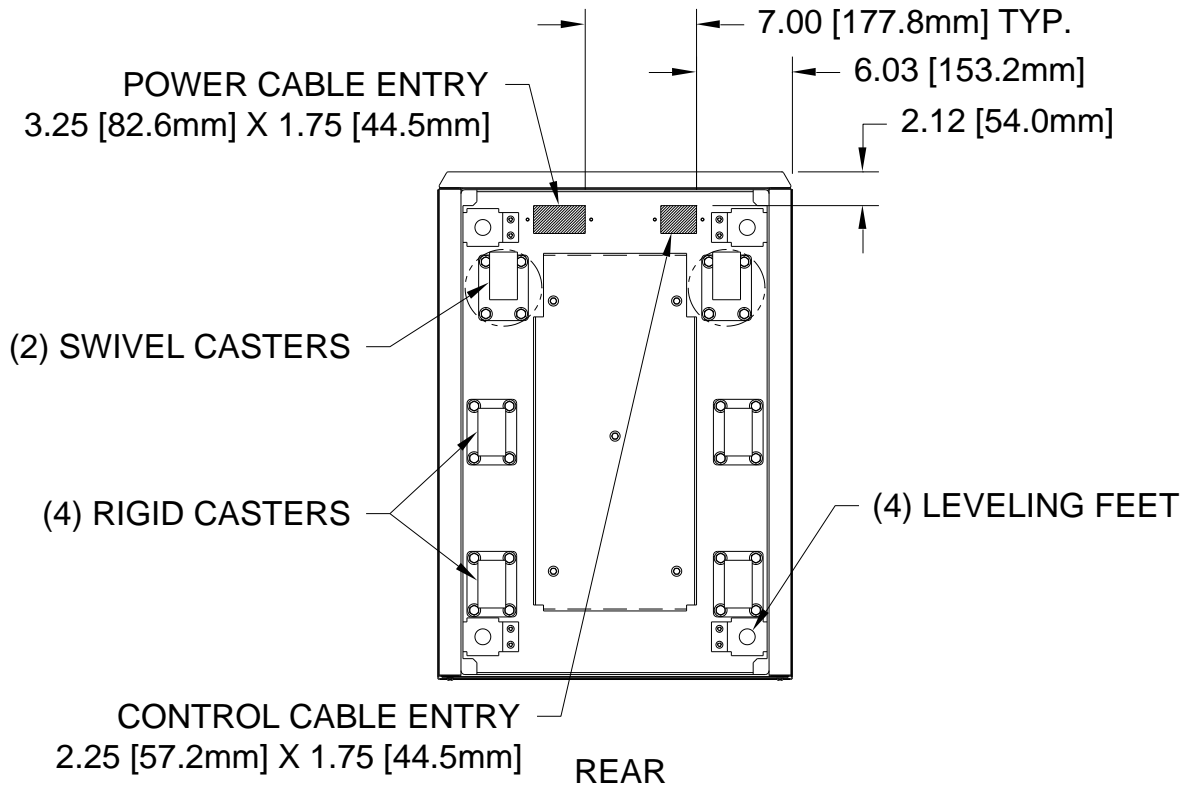

Figure 11-Bottom View, Battery Cabinet

Removing and Replacing the Front Panel

1. Pull the top of the panel outward until the ball studs unsnap.
2. Lift the panel up and off the cabinet.

To replace the panel:

1. Lower the shoulder screws at the bottom of the panel into the keyhole slots on the cabinet.
2. Press the panel inward until the ball studs snap into place.

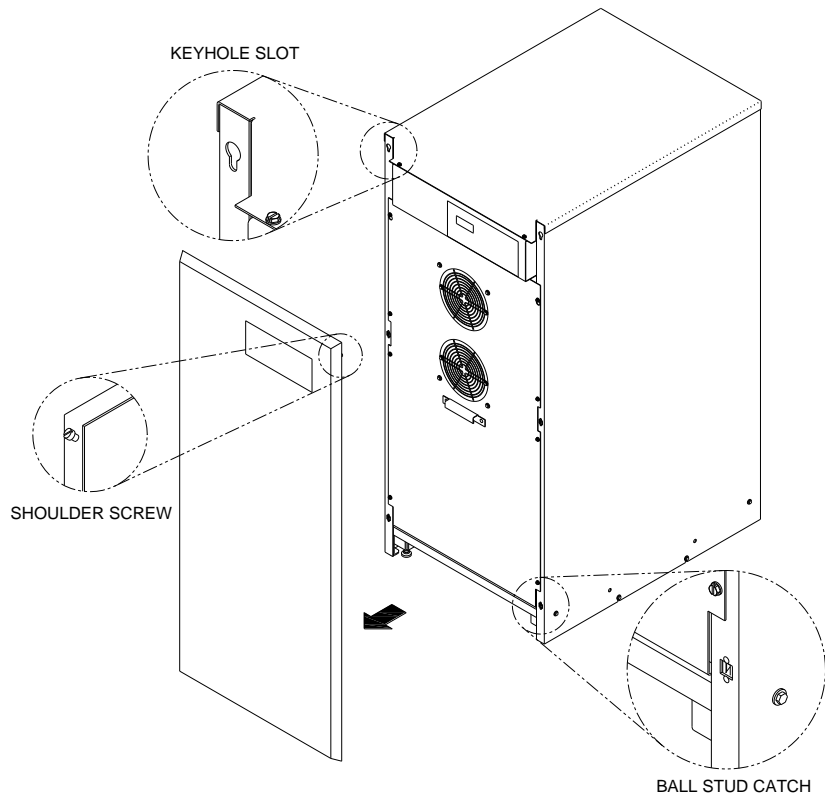

Figure 12-Removing the UPS Front Panel

Check the Internal Battery

To be performed by authorized service personnel:

1. Remove front cover panel and interior panel.
2. Remove and discard shipping support panel mounted in front of the battery trays.
3. Inspect battery trays for signs of damage. Verify that all terminal connections are sound.
4. Use a voltmeter to verify that the battery string is above 420 VDC at the battery plug shown in figure 13.
5. Verify that the positive (red) plug of the lower tray is connected to the negative (black) plug of the upper tray.



Never connect the positive red (red) plug to the negative (black) plug from the same tray. Severe damage and injury could result.

6. If the UPS has four battery trays, also check the lower two battery trays.
7. Connect the external battery to the UPS, using the procedure that follows.

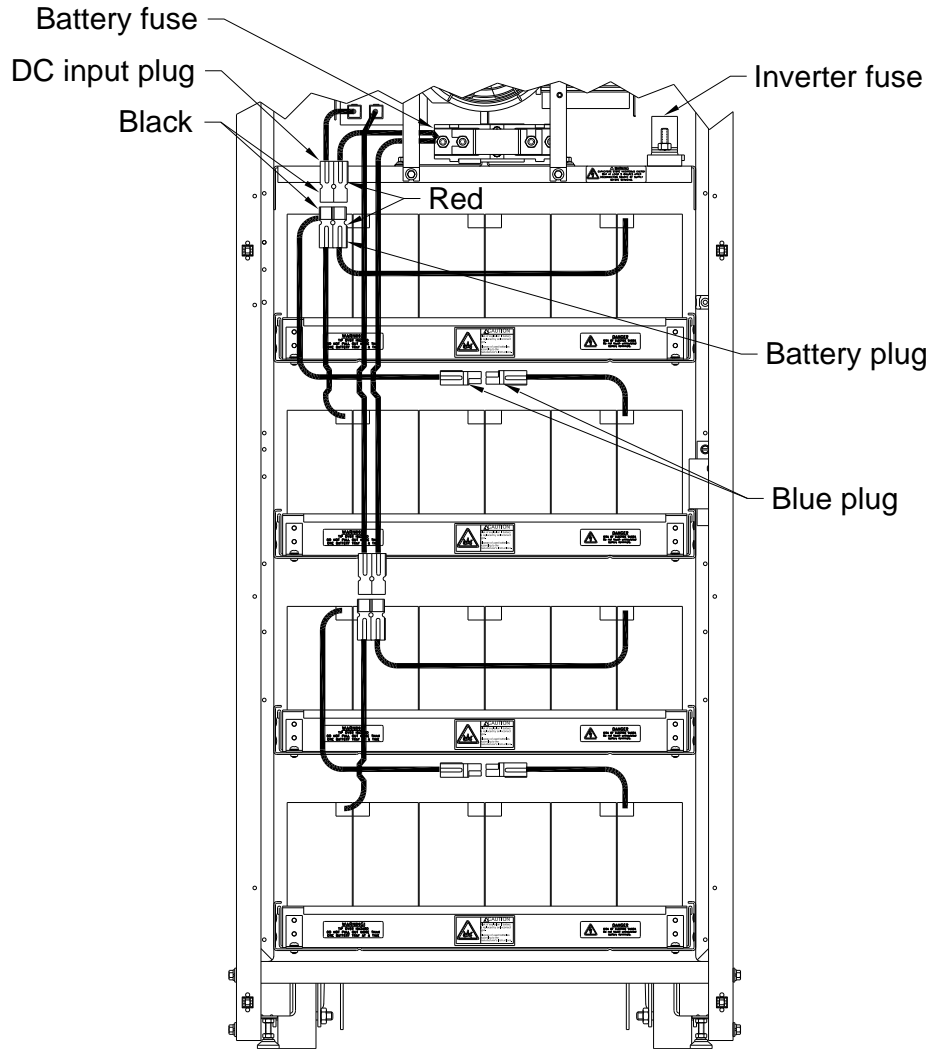

Figure 13-Internal Battery

Connecting the FirstLine Battery Cabinet to the UPS

To be performed by authorized service personnel:

1. Inspect battery trays for signs of damage. Verify that all terminal connections are sound.
2. Use a voltmeter to verify that the battery string is above 408 VDC at the battery input connector shown in figure 14.
3. Open the circuit breaker. If the cabinet is not equipped with a breaker disconnect each battery string by unplugging all of the red and black power pole connectors.
4. With wire sized per the local codes, #6 AWG 75°C copper wire minimum to #2 AWG maximum, connect to the left battery terminal block.
5. Connect the ground wire to the 1/4-20 ground stud with a ring terminal or pressure lug by removing and replacing the top nut and washers only with a 7/16" wrench.
6. If the battery cabinet is not equipped with a disconnect breaker, an external one must be provided between the battery and the UPS.
7. Repeat procedures 4 and 5 to the FirstLine UPS Extended Run Time Battery connector located in the right side of the UPS. We recommend that the wires be marked as to which is positive (+) and negative (-) to ensure that the wires are not accidentally crossed. See figure 15.

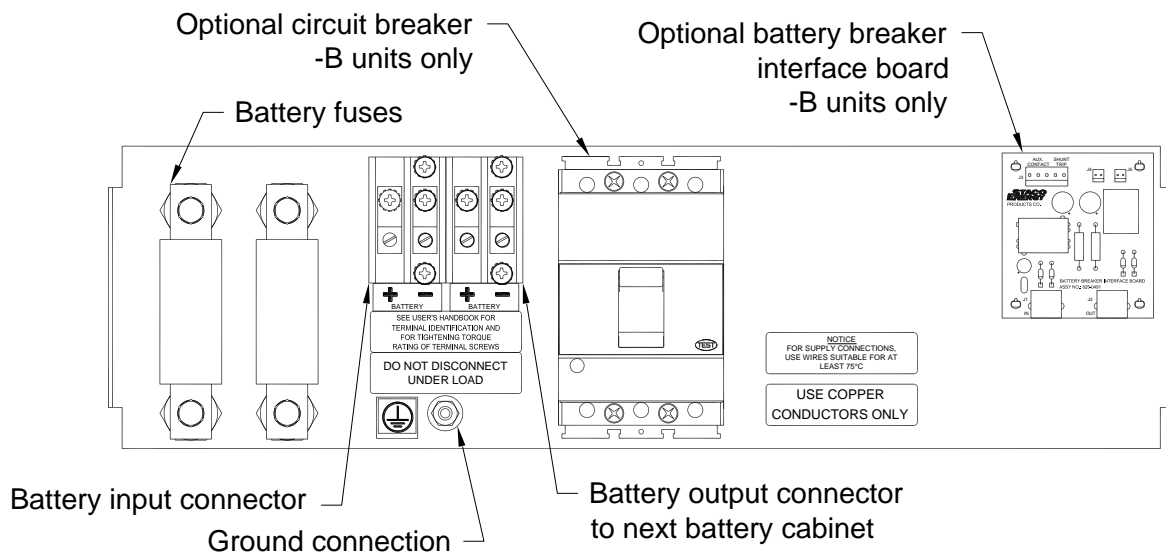

Figure 14-Input/Output Panel



Never connect the positive to the negative. Severe damage and injury could result.

BATTERY INPUT/OUTPUT TERMINAL TIGHTENING TORQUE	
#2-#3 AWG	50 inch-pounds
#4-#6 AWG	45 inch-pounds

GROUND STUD TIGHTENING TORQUE	
Extended Run Time Battery Cabinet	100 inch-pounds
UPS Cabinet	55 inch-pounds

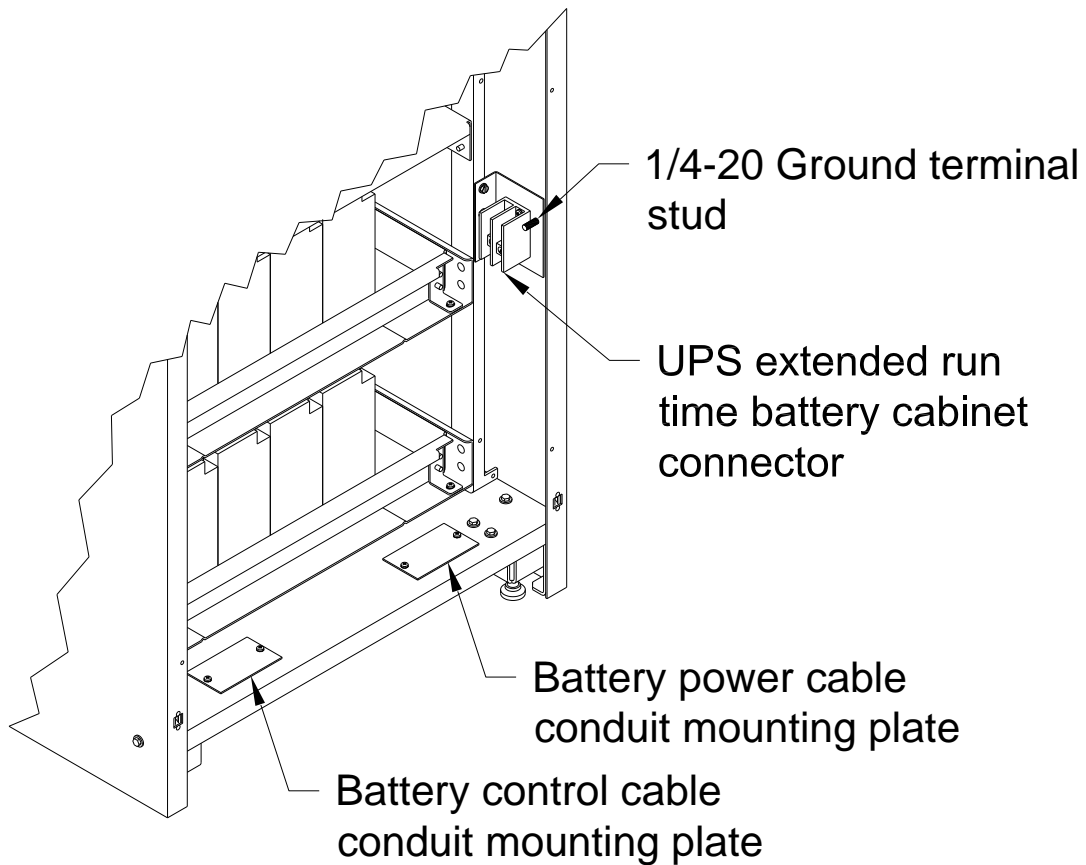

Figure 15-UPS Connections

Battery Connection, continued

8. If the system has two battery cabinets, prepare the second battery cabinet by removing the panels. Repeat steps 1 through 7 for the second cabinet. The other end of the wires from the second cabinet connect to the right-hand battery terminal block using the procedure described in steps 4 and 5.

9. If the battery cabinet is equipped with the optional circuit breaker, connect the breaker interface cable(s) as described in Section 5 of this manual, then return to this procedure.

10. If the battery cabinet does not have an internal breaker, close the external breaker. Do not close the internal breaker at this time. Connect the internal battery of the UPS by connecting the red and black battery plug to the red and black dc input plug. Refer to Figure 13. If the UPS has two internal batteries, also connect the second battery plug to the second dc input plug.

11. Referring to figure 14, at the external battery cabinet, measure the dc voltage from the left-hand fuse (positive lead of meter) to the right-hand fuse (negative lead of meter). The voltage measured should be positive. If not, the polarity of the battery connections is not correct and must be corrected. Expect to measure 400 to 445 Vdc during this test, depending on the state of charge of the battery. Repeat this test for the second battery cabinet, if present.

12. If the battery polarity is correct, open the external breaker (if equipped) and connect all of the internal red and black power pole battery connectors in both battery cabinets.

13. Install the internal covers on both battery cabinets and on the UPS.

Warning: batteries must be connected to the UPS before the rectifier is started. (The rectifier starts automatically when the UPS is turned on). All battery breakers must be closed prior to starting the UPS. If a battery breaker is opened for any reason, the UPS must be turned off before closing the breaker. Refer to section 9 for additional information.

14. Close the internal breakers and/or external breakers for the battery cabinets.

15. The UPS is now ready to be started. The outer covers can be installed as desired.



CAUTION: The battery breaker interface board is an electrostatic sensitive device. The user should be grounded when connecting to this assembly.

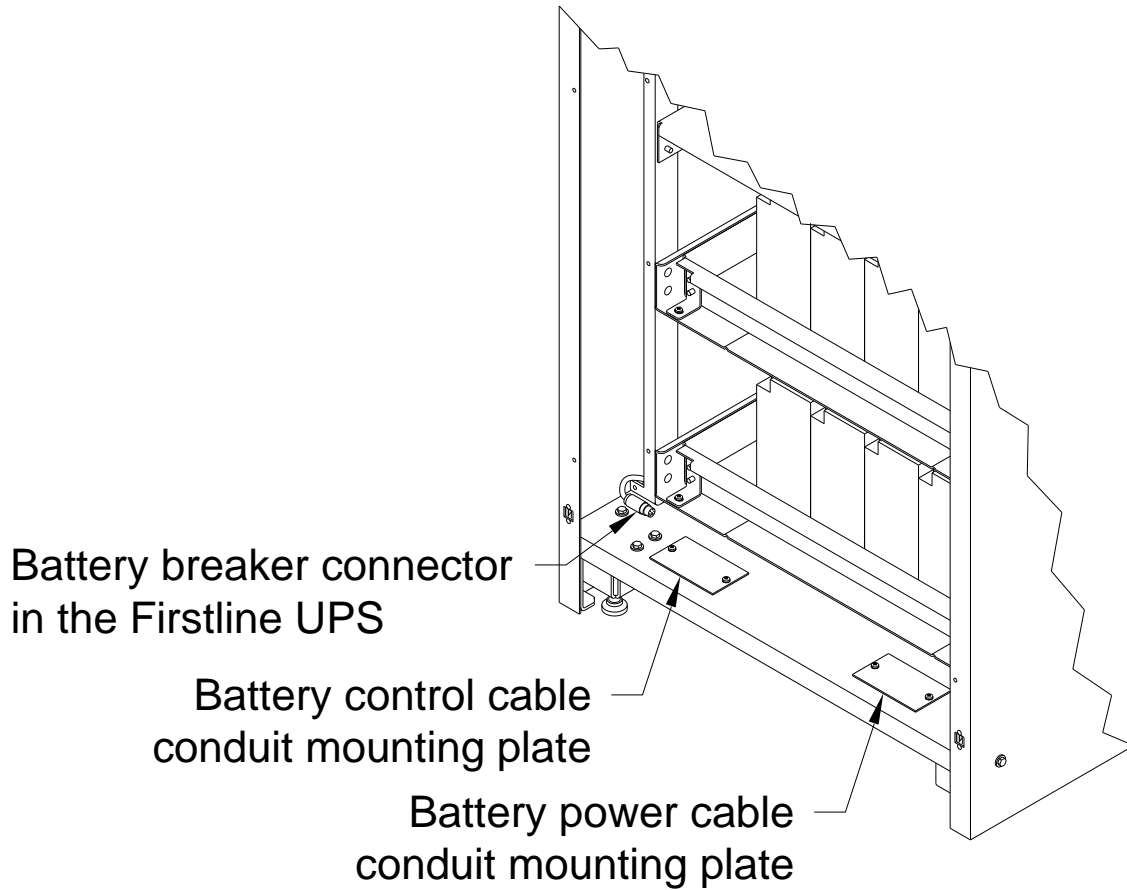

Figure 17-Battery Breaker Connector



CAUTION: If the optional circuit breaker trips, the internal batteries of the UPS are still connected and providing power to the UPS.

SECTION 6

Communication

Figure 18 shows the location of the communication options and terminals on the UPS.

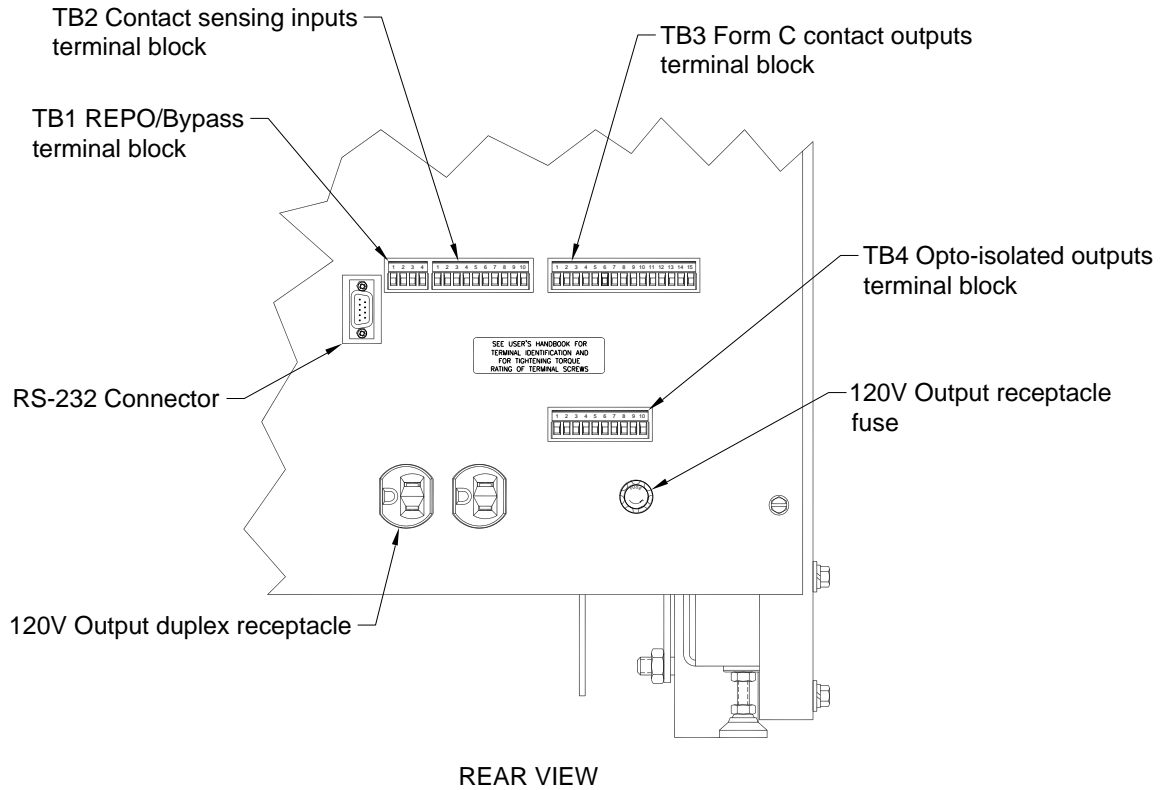

Figure 18-Communication Options and Control Terminals

120 Volt Output Duplex Receptacle

The 120 volt receptacle is only to be used to power Staco supplied communications equipment. It is imperative that no other loads be connected to this receptacle.



Note: TB1, TB2, TB3, TB4 plug-in terminal blocks, fuse, and fuse cap are shipped in the zip-lock bag with this manual. Install them before powering the UPS.

Customer Interface

The Customer Interface is located on the rear cover of the UPS. There are seven dry contact inputs that function as follows:

- TB1 terminals 1 and 2-Remote Emergency Power Off (REPO) contact closure causes immediate shutdown of the UPS. Contact the factory if a normally closed REPO switch is required.
- TB1 terminals 3 and 4-Bypass Switch Sensing. For future use.

- TB2 terminals 1 and 2-Battery Charge Inhibit. For future use.
- TB2 terminals 3 and 4-Reduced Current Operation. For future use.
- TB2 terminals 5 and 6-Automaitc Restart Inhibit. For future use.
- TB2 terminals 7 and 8-not defined.
- TB2 terminal 9 and 10-not defined.

There are five sets of form-C dry contact available as outputs. They are capable of switching up to 30 volts (AC or DC) at up to 1 amp. Listed in order of NO, COM, NC.

- TB3 terminals 1, 2, 3 – running on inverter.
- TB3 terminals 4, 5, 6- battery discharging.
- TB3 terminals 7, 8, 9- low battery reserve.
- TB3 terminals 10, 11, 12- on bypass.
- TB3 terminals 13, 14, 15- alarm present.

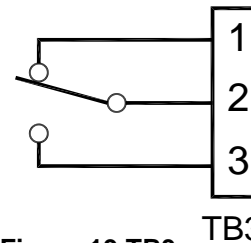

Example

Figure 19 TB3

J232 is an RS-232 DCE three wire interface. See separate specification for details. (Not currently enabled-future use).

There are five sets of optically isolated open collector outputs available. They are capable of switching up to 30 volts DC and up to 3 milliamps. Listed in order of Emitter, Collector.

- TB4 terminals 1,2 – running on inverter
- TB4 terminals 3,4 – battery discharging
- TB4 terminals 5,6 – low battery reserve
- TB4 terminals 7,8 – on bypass
- TB4 terminals 9, 10 – alarm present

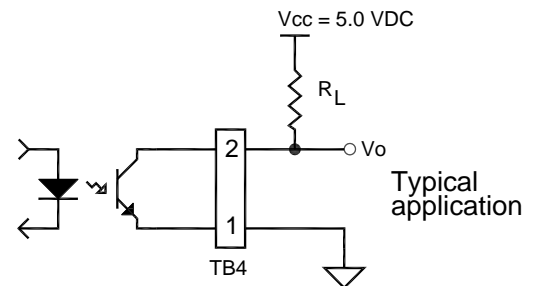

Figure 20-TB4

An RS-232 DCE three wire interface is available. The UPS shipped with an installation CD containing monitor software and an RS-232 cable. The monitor software will allow a single user to connect the UPS to a computer via the RS-232 port for local monitoring of UPS operation.

For advanced monitoring Ethernet and SNMP are supported via the RS-232 interface with an external adaptor. A 120 volt AC outlet has been provided on the back panel of the UPS for powering the external adaptor. Consult the factory for more details.

The local RS-232 monitor function cannot be used at the same time as the external monitoring adaptor.

Table 8-Torque Values for TB1, 2, 3, 4

TORQUE VALUES FOR TERMINAL BLOCKS ON CUSTOMER INTERFACE BOARD	
#22 - #12 AWG	4.4 inch-pounds

SECTION 7

Operation

This Section contains information on how to use the FirstLine UPS, including front panel operation, UPS startup and shutdown.

Control Panel Functions

The UPS has LCD with backlight. It provides useful information about the UPS itself, load status, events, measurements, and setting (see figure 21).

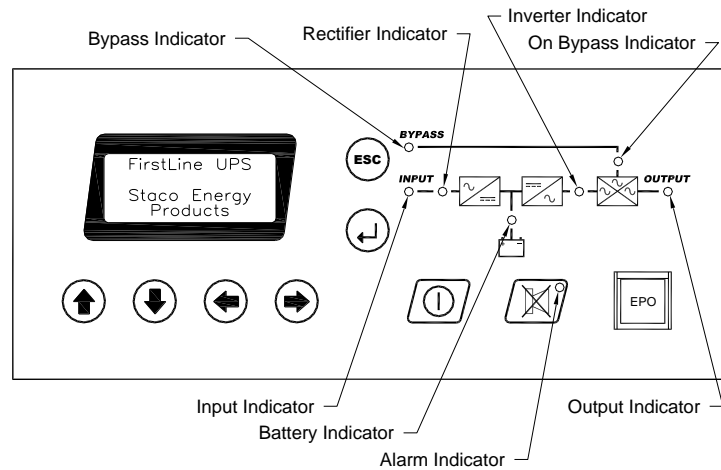

Figure 21-FirstLine Front Panel Display and Control Module

To assure that the Emergency Lighting System is functioning properly, observe the front panel display on the UPS. There are three conditions that could exist:

System Normal

(everything is working as desired)

The INVERTER indicator, the INPUT indicator, the Rectifier Indicator, the Battery Indicator, and the OUTPUT indicator will all be green. The BYPASS indicator will also be green if the input is within specification for bypass operation. During normal operation, the system will power the load with the inverter with the battery available in the event that the input fails. The battery will automatically recharge during normal operation.

On Battery

(the input is outside of specified operating range and the battery is being used to power the load)

The Battery Indicator will be yellow.

Abnormal

(the system is running on bypass or there is a fault)

If neither the SYSTEM NORMAL nor the ON BATTERY condition exists, then the system is ABNORMAL. If the system is on bypass due to an output overload, the overload must be eliminated before normal operation can be restored. Use table 9 and table 10 as guides to obtain information to determine what fault might be present.

The following table shows the indicator status and description:

Indicator	Status	Description
Bypass	Off	Bypass input voltage or frequency not qualified
Bypass	Green	Bypass input voltage or frequency qualified
Bypass	Yellow	Inverter output not synchronized to bypass input
Bypass	Red	Bypass input voltage has incorrect phase sequence
Input	Off	Rectifier input voltage or frequency not qualified
Input	Green	Rectifier input voltage and frequency qualified
Input	Red	Rectifier input voltage has incorrect phase sequence
Rectifier	Off	System OFF or Rectifier input not qualified
Rectifier	Green	Rectifier is running normally
Rectifier	Yellow	Rectifier is running at input power limit
Rectifier	Red	Rectifier failure or DC Bus Fault, call for Service
Battery	Off	System OFF
Battery	Green	Battery is being charged or is at full charge
Battery	Yellow	Battery is discharging
Battery	Red	Battery fault or no battery present
Inverter	Off	System OFF or on Bypass
Inverter	Green	Running ON INVERTER (normal mode)
Inverter	Yellow	Bus voltage out of range or tripped on over current
Inverter	Red	Inverter failure, call for service
On Bypass	Off	System OFF or not on Bypass (normal mode)
On Bypass	Green	ON Bypass
On Bypass	Yellow	On Bypass, overload present, reduce load before system shuts down
On Bypass	Red	Static Switch Failure, Do Not Operate UPS, call for Service
Output	Off	System off
Output	Green	Output is present (On Inverter or on Bypass)
Output	Yellow	Output is overloaded, reduce load before system shuts down
Output	Red	Output failed or EPO was activated or REPO was activated
Alarm	Off	No alarms are present
Alarm	Yellow	An alarm is present

Table 9-Indicator Status and Description

Display Functions

As the default or after 15 minutes of inactivity, the LCD displays the selectable startup screen. The default is the Staco Energy Products Co. logo and can be changed to the Mimic screen in the User Settings menu.

The backlit LCD automatically dims after a long period of inactivity. Press any button to restore the screen.

Use the two middle buttons (↑ and ↓) to scroll through the menu structure. Press the → button to enter a submenu. Press the ← button to select an option. Press the **ESC** button to cancel or return to the previous menu.

The following table shows the basic menu structure.

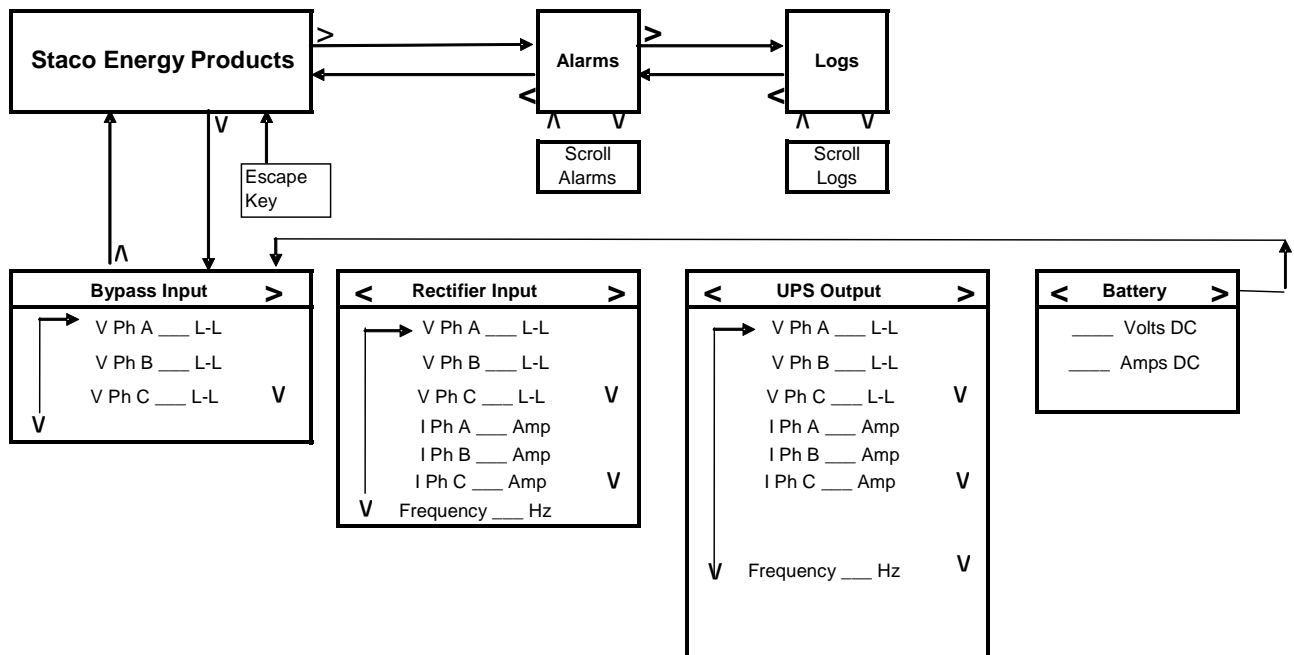



Table 10-Menu Pap for Display Functions

SECTION 8

Initial Start Up

To be performed by authorized service personnel.

1. Inspect for damage. Remove front cover panel, inner front access panel, front shipping support panel, top cover, and rear panel. Look for signs of damage due to handling including bent supports, loose components, etc.
2. Connect input power source and load to terminal blocks at rear of unit as described in Section 4. Before applying power to the UPS, verify that the correct voltage is available and that the phase sequence is correct (A-B-C).
3. If an external bypass switch is to be used, contact the factory for the correct method to interface contact sensing to the UPS.
4. Double check that there is no visible damage to the battery. Insure the battery is connected as described in Section 4.
5. Reinstall the rear cover, the top cover, and the front inner access panel. Reinstall the decorative front panel.
6. If one or more Extended Battery Cabinets are connected to the UPS, close the circuit breaker on each cabinet, if they are equipped with this option. Close the external circuit breaker for the battery, if so equipped.
7. Apply power to the UPS.
8. Press the on/off button  to start the UPS.

Normal Operation

To start the UPS, press the on/off power button . If the bypass input is qualified (voltage, frequency, and phase sequence correct), the UPS will start on bypass. The rectifier and inverter will automatically start and the static switch will transfer the load to the inverter.

To stop the UPS, press the on/off button.

In an emergency, the UPS can be stopped by lifting the guard and pressing the “EPO” button (Emergency Power Off). Activation of Emergency Power Off, either via the front panel EPO button or via the Remote Emergency Power Off function (TB1 on the Customer Interface), will also cause the system to reset, interrupting any display or communication process that is underway.

The output circuits of the UPS; should not be considered safe unless the UPS is Off AND the input power source to the UPS has been removed by opening the input disconnect device which is external to the UPS.

If one or more Extended Battery Cabinets are connected to the UPS, do not open the (optional) circuit breaker on any cabinet. If the circuit breaker is open, do not close the circuit breaker while the UPS is operating. See Section 8 for the proper procedure to close the circuit breaker.

Testing the Emergency Lighting System

This test must only be performed by authorized personnel.

Before testing the emergency lighting system, verify that the system condition is normal. The INVERTER indicator, the INPUT indicator, the Rectifier Indicator, the Battery Indicator, and the OUTPUT indicator should all be green. The BYPASS indicator will also be green if the input is within specification for bypass operation.

Gain access to the circuit breaker that supplies the UPS. Generally, this breaker should have restricted access, so that unauthorized personnel cannot disable the input to the emergency lighting system. To initiate the test, open the breaker.

The UPS should continue to operate, but the Battery indicator on the front panel will change to yellow.

To terminate the test, close the breaker that supplies power to the UPS. The UPS will return to normal operation and the Battery indicator will change back to green.

The length of the test is up to the user. A longer test gives additional confidence as to the condition of the battery, but battery life is adversely affected by the number and depth of discharges. Also, the available battery run-time is reduced as a function of the amount of energy used during the test, so the battery time available will be reduced until sufficient charging has occurred.

The front panel display can be used to observe battery voltage and current during the discharge. Multiplying the two numbers gives an approximation of the power supplied by the battery (in watts; ignore the sign of the answer, since discharge is reported as negative current).

Manual Transfer to Bypass

Verify that the bypass input is qualified by observing that the bypass indicator is green. While holding down the ESC key, press the up-arrow key. When the conditions are met for a transfer to bypass (bypass input is qualified and inverter is synchronized to bypass), the static switch will transfer the load to bypass. After a few seconds, the mimic display will update to show this.

Manual Transfer to Inverter

This procedure enables an automatic transfer to inverter. While holding down the ESC key, press the down-arrow key. When the conditions are met for a transfer to inverter (inverter is running and synchronized to bypass), the static switch will transfer the load to inverter. After a few seconds, the mimic display will update to show this.

External Bypass Arrangement

If an external bypass arrangement is to be used with the UPS, contact the factory for the proper method to interface auxiliary switches in the bypass arrangement with the UPS controls. Proper interface is mandatory to prevent damage to the UPS.

Automatic Transfer to Bypass

The static switch will automatically transfer the load to bypass if the bypass input is qualified and one of the following conditions applies:

1. Initial start-up of UPS..
2. The inverter is unable to support the load due to a) failure, b) overload, c) battery reaches end of discharge voltage.
3. Loss of output voltage is detected.

Automatic Transfer to Inverter

The static switch will automatically transfer the load to inverter if all of the following conditions are true:

1. The inverter has been started and is running normally.
2. The inverter is phase-locked to the bypass input.
3. There was no manual transfer to bypass.
5. There is no overload present.
6. There have not been more than three overload-caused transfers to bypass in a one hour period.

Over Load

Inverter

Load	Time Supported
100%	Continuous
110%	2 Minutes
125%	30 Seconds

When the overload limits are exceeded while running on inverter, an automatic transfer to bypass occurs. When the overload clears, an automatic transfer to inverter occurs, unless there have been three overloads within one hour. Inverter overload performance is not guaranteed while running on battery.

Bypass

Load	Time Supported
110%	Continuous
125%	2 Minutes
150%	10 Seconds
700%	5 Cycles

When the overload limits are exceeded while on bypass, the static switch will turn off. Note that external circuit protection devices may operate during overload conditions.

Rectifier

The rectifier is microprocessor controlled using algorithms that limit the input current to levels that protect the rectifier components. If the inverter requires more current than the rectifier can provide, the battery will supply current as needed. Thus, the rectifier will supply as much energy as is available from the rectifier input. At 80% input voltage, the rectifier can support the rated inverter load, but does not have any extra capacity to charge the battery. At higher line voltages, there is enough capacity to charge the battery while supporting rated load.

The rectifier uses an advanced high frequency Pulse Width Modulated design that presents low current distortion to the input power source. Its high power factor means that maximum power is obtained for a given input current.

SECTION 9

Battery Removal, Installation, and Service

The batteries must only be serviced by authorized service personnel.

Before any battery service is attempted, the batteries must be disconnected by unplugging the cables to the battery trays. Before unplugging the cables, the connections should be marked in a way that no confusion will exist when it is time to reconnect the cables. The batteries are mounted in slide out trays that permit access to the battery to battery connections when the trays are withdrawn from the cabinet.

If batteries are being replaced, only use the same manufacturer and battery type and rating as the battery removed.

It is very important that only one tray at a time be extended from the cabinet. If more than one tray is extended, the cabinet can become unstable and topple over.

After each tray is installed or serviced, it must be fully inserted and secured using the supplied threaded fasteners before attempting to install or service another tray.

If the trays are to be removed, always remove the highest tray first. The battery trays are very heavy and it will be necessary to use a lifting device to support the trays as they are removed. When the trays are to be reinstalled, use the procedure in the following paragraph.

WARNING

Never connect the two cables from a battery tray or from a battery string (two trays) together as severe damage will occur, resulting in fire and/or injury. Battery connections should only be made by a person wearing eye protection. It is advised that eye wash be available. If there are any doubts about the proper connections, do not proceed.

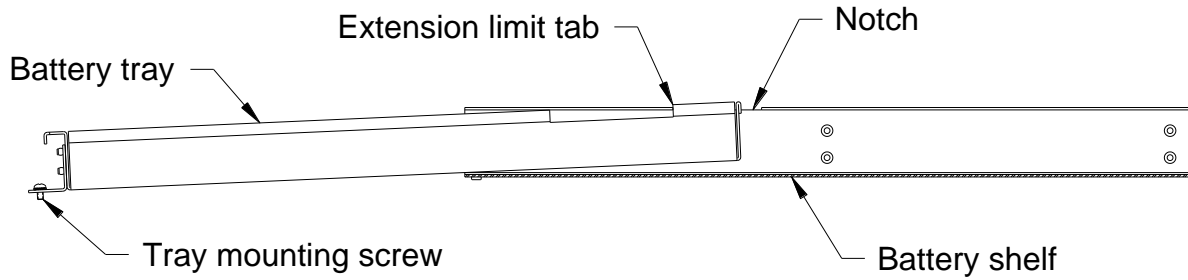

Cutaway side view of battery tray
batteries not shown for clarity

Figure 22-Battery Tray

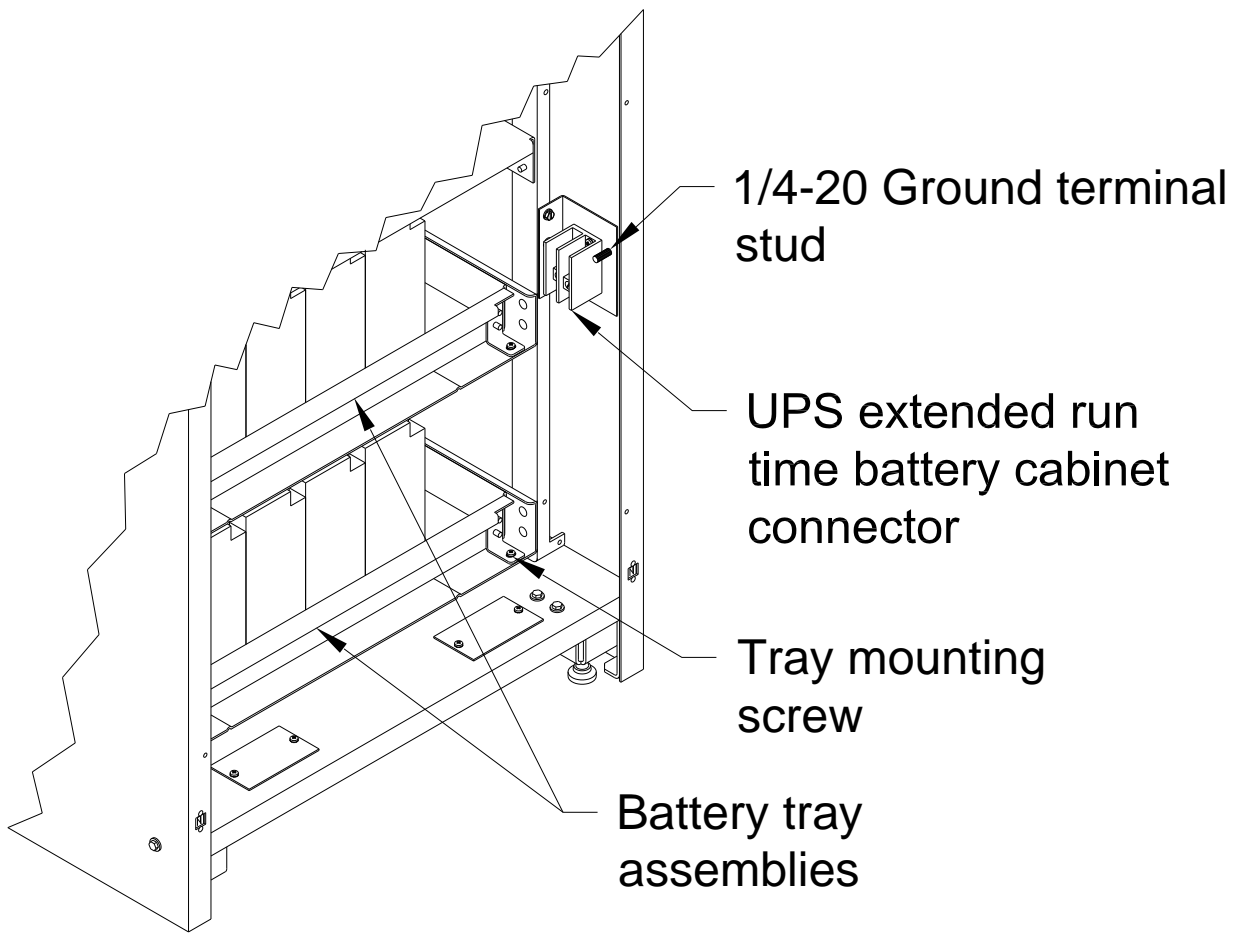

Figure 23-Battery Installation

Special Considerations for Connection Batteries to the FirstLine UPS, including Extended Run Time Battery Cabinets

It is never safe to work within either the UPS or the extended battery cabinet while the UPS is powered. The battery produces a lethal voltage whether or not the UPS is powered or running. Always work with extreme caution. No service work should be performed unless the personnel are properly trained and appropriate tools and equipment are available.

All batteries must be connected to the UPS prior to starting the rectifier. The rectifier runs whenever the UPS is on. If a battery is disconnected while the rectifier is running (for example, if the optional breaker on an extended battery cabinet is opened while the UPS is running), it must not be closed without first stopping the rectifier. This same precaution applies to opening the external user supplied battery disconnect device. If one is present. Connecting a battery while the rectifier is running will cause equipment damage that is not covered by the equipment warranty. See the procedure, below, for stopping the rectifier.

It is essential that the Extended Battery Cabinet be connected with the proper polarity. Reverse polarity will cause equipment damage that is not covered by the equipment warranty. There is a polarity verification procedure, below, that will help to prevent mishaps. Wires should be marked using colored tape to avoid confusion. Note that the terminal block in the UPS and the terminal blocks in the Extended Battery Cabinet all use the left-hand terminal for the positive connection and the right-hand terminal for the negative connection.

Before connecting the wires between the UPS and the Extended Battery Cabinet, the UPS must be powered down, the front outer panel must be removed, the front inner safety panel must be removed, and all internal batteries must be disconnected by unplugging the red and black battery plug from the DC input plug for each battery string. Most units have one battery string, but a second string is an option in the tall cabinet version. On the Extended Battery Cabinet, the front outer panel must be removed, the front inner safety panel must be removed, and all internal batteries must be disconnected by unplugging the red and black battery plugs between each battery string and the plug pair between the lowest battery string and the input/output panel. Connect the three wires (positive, negative, and ground) to the external battery terminal block and the grounding stud at the UPS end. Connect the Extended Battery Cabinet end of the three wires to the terminal block on the left and to the ground stud. The positive wire goes to the left-hand terminal and the negative wire goes to the right-hand terminal. If additional cabinets are to be added, run the three wires from the first cabinet to the second using the right-hand terminal block in the first cabinet and the left-hand terminal block in the second cabinet. If a third cabinet is present, run the three wires from the second cabinet to the third using the right-hand terminal block in the second cabinet and the left-hand terminal block in the third cabinet.

Polarity Verification Procedure

Check to make sure that all wiring is proper and secure and that all personnel are clear of hazardous circuits.

For this procedure, the UPS should be off with no power applied.

If the UPS has an internal battery, connect it to the DC input connector. If there is an external user supplied battery disconnect device, it should be closed. At the external battery cabinet, measure the dc voltage from the left-hand fuse (positive lead of meter) to the right-hand fuse (negative lead of meter). The voltage measured should be positive. If not, the polarity of the connections is not correct. (The voltage measured during this procedure should be in the range of 400 to 445 Vdc, depending on the state of charge of the battery). Repeat this measurement for the other Extended Battery Cabinets, if present. The battery plugs for all strings in the Extended Battery Cabinet(s) can be connected at this time.

If the UPS does not have an internal battery, start by connecting the plug from the lowest battery string in the Extended Battery Cabinet to the plug from the input/output panel. If there is an external user supplied battery disconnect device, it should be closed. Measure the voltage at the external battery terminal block in the UPS with the positive lead of the meter on the left-hand terminal and the negative lead of the meter on the right-hand terminal. The voltage measured should be positive. If not, the polarity of the connections is not correct. If there is a second Extended Battery Cabinet, measure the dc voltage in that cabinet from the left-hand fuse (positive lead of meter) to the right-hand fuse (negative lead of meter). The voltage measured should be positive. If not, the polarity of the connections is not correct. Repeat this measurement for the third Extended Battery Cabinet, if present. The battery plugs for all strings in the Extended Battery Cabinet(s) can be connected at this time.

Stopping the Rectifier in the UPS

Before connecting any batteries to the UPS, the rectifier must be stopped. The rectifier is stopped whenever the UPS is OFF. The batteries are disconnected whenever the optional disconnect breaker(s) in the Extended Battery Cabinet(s) is (are) open, or whenever the external user supplied battery disconnect device is open. If the Extended Battery Cabinet(s) is(are) equipped with the optional disconnect breaker, it is possible for a breaker to be opened during operation, which requires that the rectifier be stopped before closing the breaker. If the external user supplied battery disconnect device is opened during operation, it is necessary to stop the rectifier before closing the device. All breakers should be closed when the UPS is started. Generally, the only reason to open any of the battery disconnect devices is to perform service, which requires that the UPS be turned off. It is best to close the disconnect devices before starting the UPS and leave them closed during operation. In the event of an emergency condition that requires opening a disconnect device, it will be necessary to stop the rectifier in order to restore the system to normal configuration.

The simplest way to stop the rectifier is to turn off the UPS by pressing the power ("line-circle") button on the front panel. This will remove power from the load. Once the battery breaker(s) has (have) been closed, the UPS can be restarted by pressing the power button.

If the UPS is connected to the load using a Maintenance Bypass Switch (MBS), the load can be maintained when the UPS is turned OFF.

To transfer to MBS:

1. Verify that the bypass source is available (Bypass lamp on UPS mimic display is green).
2. Perform a manual transfer to bypass mode on the UPS by pressing and holding the ESC key while simultaneously pressing the UP-ARROW key.
3. Verify that the UPS output is ON BYPASS by observing that the lamp associated with the bypass line at the static switch block on the mimic display is green and that the lamp associated with the inverter is not lit.
4. Operate the MBS to put it in bypass mode.

It is now safe to turn off the UPS and close the battery breaker(s). Restart the UPS. To transfer back to normal mode:

1. Verify that the UPS is still ON BYPASS by observing the mimic display. If not, perform a manual transfer to bypass as described, above.
2. Operate the MBS to put it in normal mode.
3. Enable automatic transfer by pressing and holding the ESC key while simultaneously pressing the DOWN-ARROW key. After a few seconds, the mimic display should show that the static switch has transferred the load to inverter.

UPS Maintenance

The FirstLine UPS is designed to be virtually user maintenance free, requiring only the occasional wipe with a damp cloth or non-abrasive cleaner.

Spare kits are available for the FirstLine UPS series, please contact Staco Energy Products Co. service center for details.

For maximum availability of the UPS, the components that are subject to wear should be replaced as part of a comprehensive preventive maintenance program:

RECOMMENDED REPLACEMENT INTERVALS	
Dc Filter Capacitors	5 years
AC Filter Capacitors	5 years
Fans	2 years
Rectifier Chokes	10 years
Batteries	2 to 5 years ¹

REPLACEMENT BATTERY		
Manufacturer	Cat. Number	Quantity Required
China Storage Battery	HRL1280W	34 per string
China Storage Battery	HR1290W	34 per string

All servicing should be performed by qualified service personnel.

¹ Battery life is highly dependent on the ambient temperature and the number and depth of discharge cycles. A discharged battery should be recharged as soon as possible. If the battery is left in a discharged state, irreversible sulfation occurs, reducing the capacity (run-time) of the battery.

SECTION 10

FirstLine UPS Technical Specifications

Table 11-Technical Specifications

UPS Rating KW	8	12	16
Input			
Voltage	208Y, 480Y Three phase plus ground; 208 Delta, 480 Delta with optional isolation transformer (-I models)		
Start-up Range	+10% - 10% From Nominal		
Operating Range	+10% - 15% From Nominal		
Frequency	57-63 Hz		
Power Factor	> 0.98 At Full Load		
Current Distortion (THD)	< 5% At Full Load		
Input Current	Nominal: 28	40	52
(at 208V, Non-Isolated)	Maximum: 41	55	69
Input Current Inrush	Walk-In from 25% maximum to 100% full load rating in 5 seconds		
Output			
Voltage	208Y, 480 Three Phase 4 wire plus ground		
Frequency	60 Hz +/- 0.01%		
Voltage Regulation	+/- 1% balanced load, +/- 3% with 100% unbalanced load		
Voltage Transient Response	< 5% voltage change for 100% load step with recovery to less than 2% in less than 1 cycle		
Voltage Distortion THD	< 2% with linear load, < 5% with 100% non-linear load		
Inverter Overload	100% continuous, 125% for 2 minutes, 150% for 1 second		
Bypass Overload	110% continuous, 125% for 2 minutes, 150% for 10 seconds, 700% for 5 cycles		
Output Current (Amp's at 208V)	22	33	44
Heat Rejection (BTU/Hr)	6800	7500	8200
Battery Operation²			
Run time on battery	90 minutes	90 minutes	90 minutes
Rated recharge time	168 hours	168 hours	168 hours
Typical recharge time	24 hours	24 hours	24 hours
Environmental			
Altitude	Derate load capability above 1000 meters 1% per 100 meters.		
Maximum Operating Temperature	40° C		
Non-Operating Temperature	-20 to + 60° C. Exceeding 0 - 40° C will degrade battery life.		
Dimensions and Weights (mm) (Kg)			
Refer to Figures 1 and 2 in Section 1 and Table 3 in Section 3			
Standards			
208V and 480V Models	UPS UL listed to 1778, NEMA PE-1, ASME, ASA-C-39.1-1984, FCC Part 15 Subpart J Class B, NEC, OSHA, IEEE587, ANSI C 62.41-1980, ISO9000. System listed to UL 924		

² Run time is approximate and depends on the battery state of charge, age, operating temperature and other conditions.