

FirstLine P Maintenance Bypass Switch Cabinet  
For 80kVA - 125kVA with 480V Input/Output

---

***User's Manual***



301 Gaddis Boulevard • Dayton, Ohio 45403  
U.S. Toll Free 866-261-1191  
(937) 253-1191 • Fax: (937) 253-1723  
Web site: [www.stacoenergy.com](http://www.stacoenergy.com)



**Table of Contents**

SECTION 1 ..... 1  
 Introduction..... 1  
 Overview..... 1  
 Applicability..... 2  
 Part Numbers ..... 2  
 Section 2 ..... 3  
 SAFETY WARNINGS ..... 3  
 DANGER ..... 3  
 WARNING ..... 3  
 CAUTION ..... 4  
 Section 3 ..... 5  
 Cabinet Setup..... 5  
 Inspecting the Equipment ..... 5  
 Floor Loading..... 5  
 CLEARANCES ..... 5  
 Unloading the Cabinet(s) ..... 6  
 Attaching the Cabinet to the UPS ..... 7  
 Section 4 ..... 8  
 Electrical Installation ..... 8  
 Wiring Preparation ..... 8  
 Control Connections ..... 11  
 Terminal Strip Torque Requirements..... 12  
 Switch Settings ..... 12  
 SECTION 5 ..... 14  
 Remote EPO (Emergency Power Off) ..... 14  
 Section 6 ..... 16  
 Operation..... 16  
 Maintenance Bypass Switch (MBS)..... 16  
 REPO ..... 19  
 Section 7 ..... 22  
 Maintenance ..... 22  
 Section 8 ..... 23  
 FirstLine P Maintenance Bypass Switch Technical Specifications ..... 23

Table 1 - Symbols ..... 4  
 Table 2 - Model Floor Loadings..... 5  
 Table 3 - Wire Size Requirements ..... 9  
 Table 4 - Maximum Current Ratings..... 10  
 Table 5 - Terminal Tightening Torques ..... 10  
 Table 6 - Maintenance Bypass Switch States ..... 20  
 Table 7 - Maintenance Bypass Switch State Change Procedures ..... 21  
 Table 8 - Technical Specifications..... 23

Figure 1 - The FirstLine P Maintenance Bypass Switch Cabinet..... 1  
Figure 2 - Pallet Mounting Hardware..... 6  
Figure 3 - Cabinet to Cabinet Mounting Hole Locations ..... 7  
Figure 4 - Inside Front View of Maintenance Bypass Switch Cabinet ..... 9  
Figure 5 - Options Control Board Assembly ..... 13  
Figure 6 - Customer Low Voltage Connection Terminal Block ..... 13  
Figure 7 - Circuit Breaker Sequence Label ..... 19

# SECTION 1

## Introduction

### Overview

The FirstLine P Maintenance Bypass Switch Cabinet for 80 kVA, 100 kVA, 125 kVA with 480 V Input and Output is a steel cabinet that attaches to the side of the UPS cabinet, thereby extending the cabinet, and providing the maintenance bypass function. The cabinet has conduit attachment points at the top and the bottom for maximum flexibility in wiring the source and load power connections. Please refer to figure 1 for the outline drawing of the cabinet.

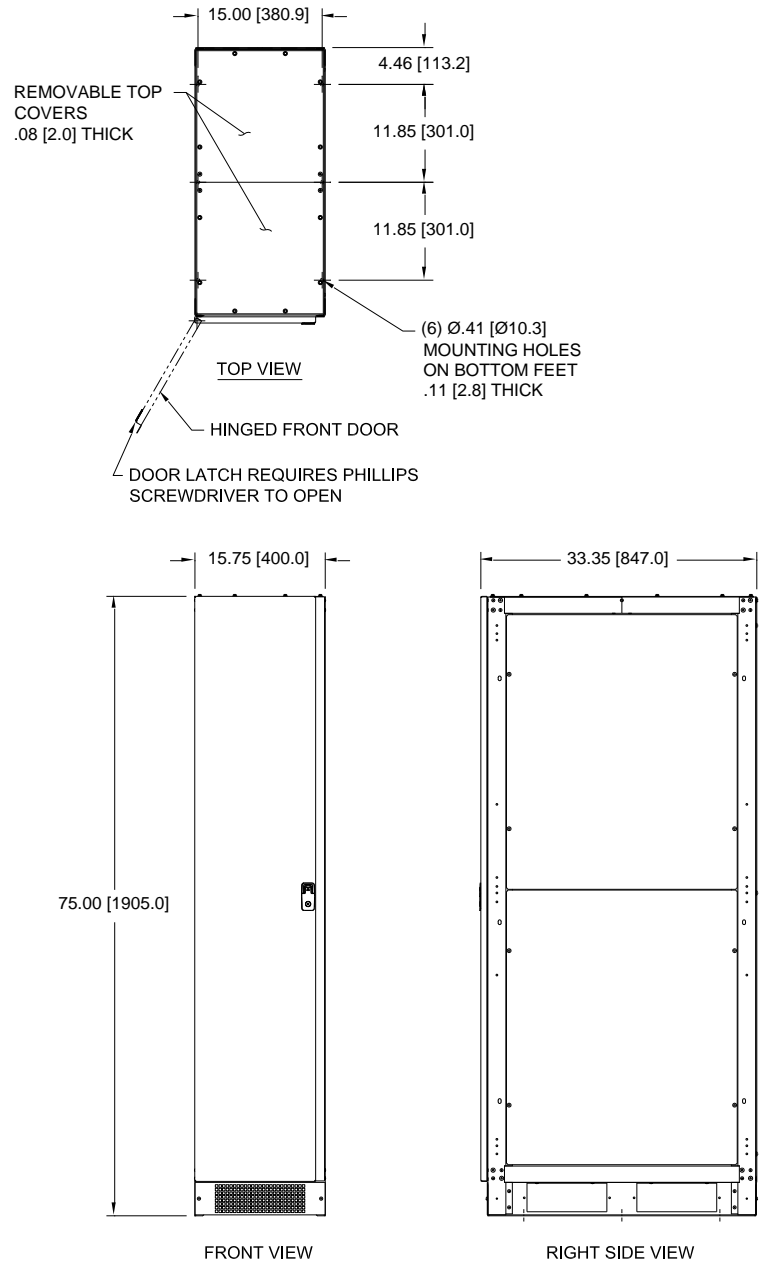

Figure 1 - The FirstLine P Maintenance Bypass Switch Cabinet

## **Applicability**

This equipment can be applied to UPS models FLU-080-00, FLU-100-00, and FLU-125-00. These UPS models operate at 480 V, 60 Hz and can be wired as delta in and delta out (3 wire plus ground) or wye in and wye out (4 wire plus ground).

For installations requiring other voltages or other wiring configurations, the equipment covered by this manual is not appropriate. Please contact Staco Energy Products Company for recommendations regarding the proper equipment.

It is permissible to use a larger Maintenance Bypass Switch Cabinet (MBS) than is required for the UPS, but special installation requirements must be met: the power source connected to the MBS must include circuit protection as specified for the input in the UPS manual and an output breaker must be provided per the UPS manual. For example, if a 125 kVA MBS is applied to an 80 kVA UPS, a 150 A breaker must be provided at the power source and a 150 A breaker must be provided between the MBS and the load. If the MBS rating matches the UPS rating, then the breakers that form the MBS switch arrangement satisfy the input and output breaker requirement for the UPS.

## **Part Numbers**

FLU-P-80-MBPS for use with 80 kVA UPS

FLU-P-100-MBPS for use with 100 kVA UPS

FLU-P-125-MBPS for use with 125 kVA UPS

## **SECTION 2**

### **SAFETY WARNINGS**

#### **IMPORTANT SAFETY INSTRUCTIONS SAVE THESE INSTRUCTIONS**

#### **READ AND FOLLOW ALL SAFETY INSTRUCTIONS**

- Do not use outdoors.
- Do not route wiring across or near hot surfaces.
- Do not install near gas or electric heaters.
- Equipment should be installed where it will not readily be subjected to tampering by unauthorized personnel.
- The use of accessory equipment not recommended by the manufacturer may cause an unsafe condition.
- Do not use this equipment for other than intended use.
- This equipment connects to the output of an uninterruptible power supply. Hazardous voltages may be present even when the electrical supply to this equipment is turned off.
- If equipped with a maintenance bypass switch, control connections between this equipment and the ups must be present to prevent the possibility of backfeed.
- Read and follow the instructions that came with the associated UPS or emergency lighting system before operating this equipment.

#### **DANGER**

This equipment contains lethal voltages. All repairs and service should only be performed by authorized service personnel. There are no user serviceable parts inside this equipment. Operation of switches and breakers require access to the cabinet interior and should only be performed by qualified personnel exercising appropriate caution.

#### **WARNING**







This equipment connects to the output of a UPS which contains its own energy source (batteries). The UPS output may carry live voltage even when the UPS is not connected to an ac supply.

To reduce the risk of fire and electric shock, install this equipment in a humidity controlled, indoor environment, free of conductive contaminants. Do not operate near water or excessive humidity (95% maximum). If condensation is present, the equipment must be allowed to completely dry before operation.

**CAUTION**

The UPS associated with this equipment contains batteries. Batteries can present a risk of electrical shock or burn from high short circuit current. Observe proper precautions. Servicing should only be performed by qualified service personnel knowledgeable of batteries and the required precautions. Keep unauthorized personnel away from batteries. Read, understand, and follow all instructions in the ups manual before attempting any operations involving the battery.

**Table 1 - Symbols**

	<p>Danger / Risk of Electric Shock</p>
	<p>Caution</p>
	<p>Risk of Explosion</p>
	<p>Note</p>
	<p>Ground Connection</p>
	<p>Electrostatic Sensitive Device</p>

## SECTION 3

### Cabinet Setup

This SECTION describes:

- Equipment inspection
- Floor loading and clearances
- Removing and replacing the cabinet panels
- Unloading the cabinet(s)
- Attaching the cabinet to the UPS

### Inspecting the Equipment

If any equipment has been damaged during shipment, keep the shipping and packing materials for the carrier or place of purchase and file a claim for shipping damage. If you discover damage after acceptance, file a claim for concealed damage.

To file a claim for shipping damage or concealed damage: 1) File with the carrier within 15 days of receipt of the equipment, 2) Send a copy of the damage claim within 15 days to your service representative.

### Floor Loading

When planning the installation, consider the battery cabinet weight for floor loading. The strength of the installation surface must be adequate for point and distributed loading. The approximate weights are shown in the following table.

**Table 2 - Model Floor Loadings**

STANDARD MODEL FLOOR LOADING		
MODEL	MAXIMUM WEIGHT	POINT LOADING
FLU-P-80-MBPS	245 lbs (111 kg)	4 lb/in <sup>2</sup> (0.3 kg/cm <sup>2</sup> )
FLU-P-100-MBPS	250 lbs (113 kg)	4 lb/in <sup>2</sup> (0.3 kg/cm <sup>2</sup> )
FLU-P-125-MBPS	250 lbs (113 kg)	4 lb/in <sup>2</sup> (0.3 kg/cm <sup>2</sup> )

### CLEARANCES

The following clearances are recommended for the FirstLine P Maintenance Bypass Switch Cabinet.

From Front of Cabinet	36" (91.4 cm) working space
-----------------------	-----------------------------

## Unloading the Cabinet(s)

The following tools are required for unloading the cabinet(s):

- Wrenches for 3/8" lag bolts.
- Forklift or pallet jack

### CAUTION



The cabinets are heavy (see Table 2). Unloading the cabinets requires at least two people to safely remove the cabinets from the pallet.

To remove the Maintenance Bypass Switch cabinet from the ship pallet:

1. Make sure the forklift is rated for the cabinet weight.
2. Make sure the path traveled has sufficient support for the combined weight of the forklift and the cabinet.
3. Make sure forks are at maximum separation.
4. Use a very strong ratchet strap (or similar device) of sufficient strength to tie the upper part of the cabinet to the forklift tower before moving.
5. Keep people out of the fall zone. If the cabinet topples over, stand clear
6. With a Phillip's screwdriver, remove the two kick panels. These will be remounted when the cabinet is in place.
7. Remove all banding, wrapping and foam protection.
8. Remove the six 3/8" lag bolts securing the cabinet to the pallet. See figure 2.



**Figure 2 - Pallet Mounting Hardware**

9. Lift the cabinet with a forklift one to two inches (1"-2" [2.5-5cm]) above the pallet.
10. Slide the pallet completely away from the raised cabinet.

11. Carefully move the cabinet to the desired location and slowly lower the cabinet to the floor or other appropriate flat surface.
12. Remount the two kick panels.

**Attaching the Cabinet to the UPS**

The Maintenance Bypass Switch cabinet was constructed so that it can be mounted to the side of the UPS cabinet if desired. To attach the Maintenance Bypass Switch Cabinet to the UPS Cabinet:

1. Remove left side panel of UPS and save hardware.
2. Butt right side of MBS cabinet up against the left side of the UPS.
3. Bolt the cabinets together at (6) locations with the supplied 5/16 hardware through the slots noted as "A" in figure 3.
4. Mount left side panel of UPS on the left side of the MBS cabinet using the hardware from the UPS.

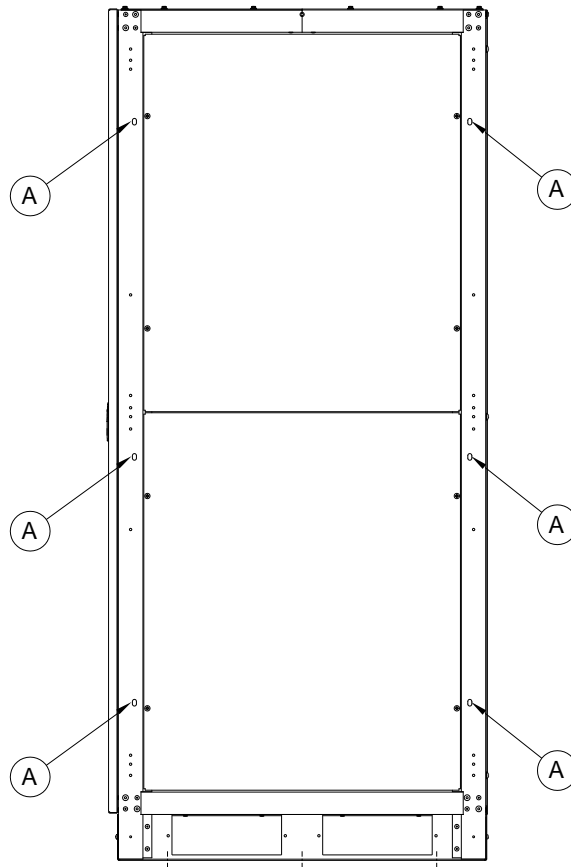

RIGHT SIDE VIEW

**Figure 3 - Cabinet to Cabinet Mounting Hole Locations**

## SECTION 4

### Electrical Installation

#### Overview

Each of the pieces of equipment covered by this manual has four sets of power connections:

1. Input from the power source, typically, from the electric utility.
2. Power routed to the input of the UPS.
3. Power from the output of the UPS.
4. Power to the load

There are four control connections between the Maintenance Bypass Switch Cabinet and the UPS that must be made. The required control connections are described later in this section.

A user accessible disconnect device must be provided (by other's) between the output of this cabinet and the load. Refer to Table 4 for current requirements.

#### WARNING



Only qualified service personnel (such as a licensed electrician) should perform the installation and initial startup. There is a risk of electrical shock.

#### Wiring Preparation

1. Verify that the equipment is the proper type. The equipment covered by this manual is 480 V 60 Hz input and output, only. The Maintenance Bypass Switch Cabinet (MBS) can be used in delta-delta or wye-wye applications, but the UPS must be properly configured (refer to the UPS manual). For delta-delta applications where an input neutral is not provided, the output neutral connection must not be used and the MBS to UPS neutral connections should be omitted.
2. Plan the locations of conduits. Two Conduit landing plates are provided at the top (see figure 1) and bottom of the cabinet. Connections between the MBS and UPS must be made at the bottom. As noted above, there are four sets of power connections and one set of control connections. The low voltage control connection wires must be routed through the wire duct below the terminal block to the bottom landing plate in the rear of the cabinet to ensure physical separation between them and the power wiring.
3. All wiring is to be in compliance with all applicable codes.

4. Verify that the source circuit capability is in compliance with the requirements shown in Table 3 and 4.
5. Select wire size in compliance with Table 3.

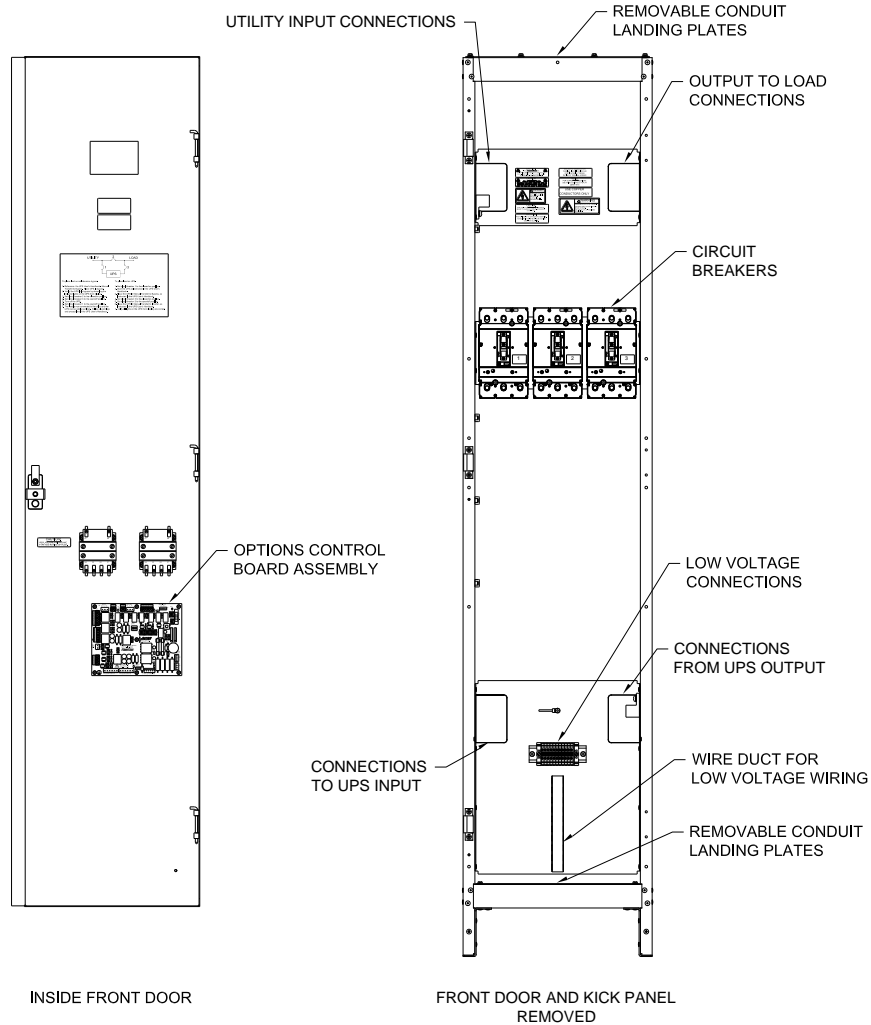

Figure 4 - Inside Front View of Maintenance Bypass Switch Cabinet

Table 3 - Wire Size Requirements

\*Wire must be rated 75°C or higher

kVA Rating	Minimum Input Wire Size	Minimum Output Wire Size	Minimum Ground Wire Size	Required Supply Breaker
80	2/0 AWG	1/0 AWG	6 AWG	150 A
100	3/0 AWG	2/0 AWG	6 AWG	175 A
125	250 kcmil	4/0 AWG	4 AWG	200 A

**Table 4 - Maximum Current Ratings**

<b>kVA Rating</b>	<b>Rated Input Current (Amps)</b>	<b>Rated Output Current (Amps)</b>
80	109	96
100	136	120
125	160	150

**Table 5 - Terminal Tightening Torques**

**INPUT / OUTPUT TERMINAL TORQUE**

<b>Wire Size</b>	<b>Torque</b>
#4 AWG – 350 kcmil	275 inch - pounds

**GROUND LUG TORQUE**

<b>Wire Size</b>	<b>Torque</b>
#6 AWG – 350 kcmil	275 inch - pounds

**LOW VOLTAGE TERMINAL TORQUE**

<b>Wire Size</b>	<b>Torque</b>
# 26-10 AWG	5.3 – 7.0 inch - pounds

**Wiring Installation**

1. Switch off utility power to the distribution point where the UPS will be connected. Be absolutely sure that there are no hazardous voltages present. Use lockout/tagout procedures to assure safety.
2. Remove as many panels as needed for adequate access for wiring the cabinet. Open the front door of the MBS Cabinet.
3. Connect wires from the "TO UPS INPUT" terminal block to the input terminals in the UPS. (Refer to the UPS manual). The wire must be in compliance with Table 3 and the terminals must be torqued in compliance with Table 5. Make sure that phase A connects to phase A and so on.
4. Connect wires from the "FROM UPS OUTPUT" terminal block to the output terminals in the UPS. (Refer to the UPS manual). The wire must be in compliance with Table 3 and the terminals must be torqued in compliance with Table 5. Make sure that phase A connects to phase A and so on.
5. Connect wires from the "OUTPUT TO LOAD" terminal block to the load. The load may be an external distribution panel, etc. If neutral is not needed by the load, then it does not need to be supplied. The wire must be in compliance with Table 3 and the terminals must be torqued in compliance with Table 5. Make sure that phase A connects to phase A and so on.

6. A set of four or six control connections must be installed from the "CUSTOMER LOW VOLTAGE CONNECTION TERMINAL BLOCK" to the Remote Commands and Alarm Connections in the front of the UPS cabinet. These control wires must be physically separated from any power wires. The length of the control wires is limited to 30 feet or 10 meters. These connections are described later in this section.
7. Verify that the input power source is not powered. Connect wires from the "UTILITY INPUT" terminal block to the input source power from the building distribution. The wire must be in compliance with Table 3 and the terminals must be torqued in compliance with Table 5. Make sure that phase A connects to phase A and so on. The source needs to have A-B-C phase sequence. If not, exchange two of the phase connections to correct this.
8. Check all work. Replace the panels that were removed for access

### **Control Connections**

Four control connections must be made between the Maintenance Bypass Switch Cabinet (MBS) and the UPS in order to provide backfeed protection, a required safety feature. There is also a provision to provide Remote Emergency Power Off (REPO). REPO causes the output breaker to trip, thereby removing power from the load. If the bypass path is active, then REPO trips the bypass breaker, removing power from the load. The UPS is also equipped with a REPO input, but that is a separate system and will require an additional contact (normally closed) on the REPO activation switch, if UPS REPO is desired (refer to the UPS manual).

The wiring to these low voltage ("ELV") connections must be kept separated from the higher voltage wiring. Refer to figures 4 and 6 regarding the Low Voltage Terminal Block and to the UPS manual that shows the connection point in the UPS. Details regarding these connections are described below.

#### **Connections Between the Maintenance Bypass Switch Cabinet and the UPS**

Since these wires affect the operation of the UPS, they should be protected. Running them in conduit is a good idea, even if local codes do not require conduit. It is also recommended that the wires are shielded twisted pairs. Alpha 6010C is a shielded cable with three twisted pairs and is available from a number of sources in various spool lengths.

Two pairs are required:

Pair 1 -- First wire from terminal 3 of the Low Voltage Connection Terminal Block (LVTB) of the Maintenance Bypass Switch Cabinet to terminal 11 of the Remote Commands and Alarms Connections on the UPS (RCA-UPS). Second wire from terminal 4 of LVTB to terminal 12 of RCA-UPS.

Pair 2 – First wire from terminal 10 of LVTB to terminal 1 of RCA-UPS. Second wire from terminal 11 of LVTB to terminal 2 of RCA-UPS.

Figure 6 is an electrical wiring schematic summarizing the connections to the Low Voltage Connection Terminal Block.

The REPO switch connections are also shown. Please note that typically only one of the REPO switch contacts is connected, depending on user preference, but both are shown to illustrate the wiring. The normally open switch connects across terminals 5 and 6 while the normally closed switch connects across terminals 8 and 9. Terminal 7 has a limited amount of unregulated dc power available to power an LED lamp to permit the use of a lighted switch for REPO. Contact Staco Energy Products Company for details if you desire to use this feature. Please also note that the Options Control Board in the MBS must be properly configured for the normally closed REPO switch to work.

### **Terminal Strip Torque Requirements**

The terminals on the Customer Low Voltage Connection Terminal Block must be torqued to 5.3 to 7.0 inch-lbs. The terminals on the Control Connections (on the UPS) must be torqued to 4.4 inch-lbs.

### **Switch Settings**

Switch "S2" on the Options Control Board (refer to Figure 5) is a four position "DIP" switch that has four small rocker switches. Pushing on the top half of each switch section closes the switch and turns it ON, pushing on the lower half turns the switch OFF. There are labels on the board to help identify the switch section.

The first section "PLT" enables "Power Loss Trip" (or Manual Restart), and should be OFF unless you want the Bypass and Inverter Output Breakers to trip on loss of power.

The second section "NCR" enables the Normally Closed REPO input and should be OFF unless there is a normally closed REPO switch connected.

The third section "OTT" is not implemented and should be turned OFF to avoid confusion.

The fourth section is not used and should be turned OFF to avoid confusion.

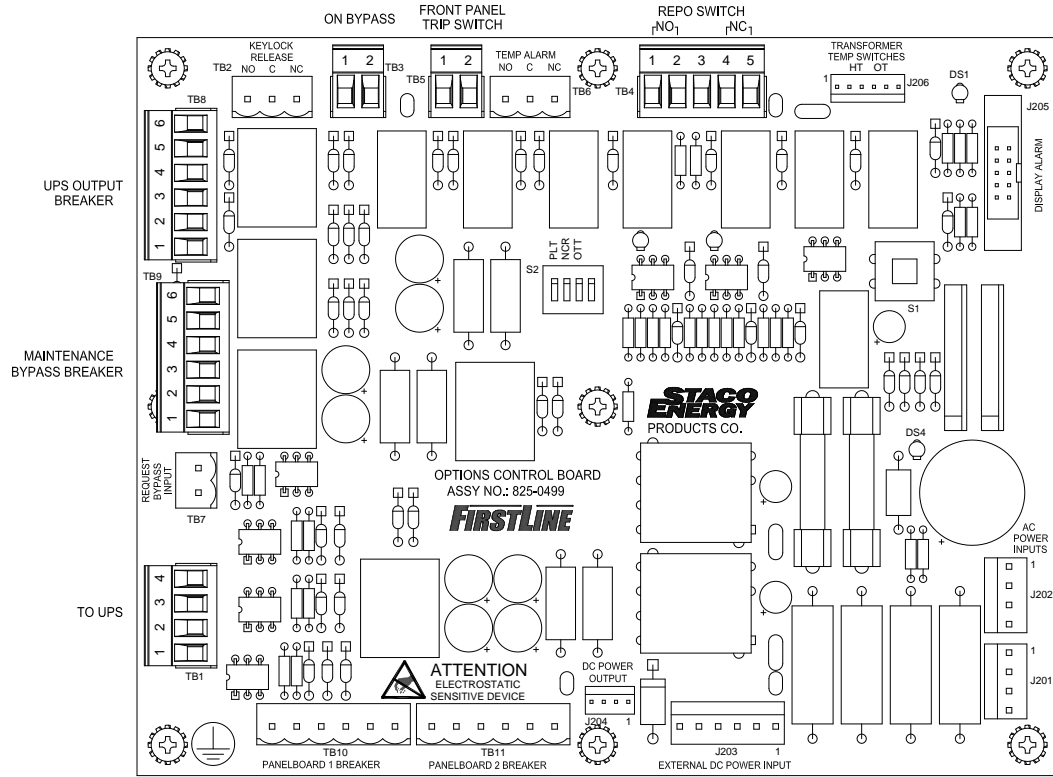

Figure 5 - Options Control Board Assembly

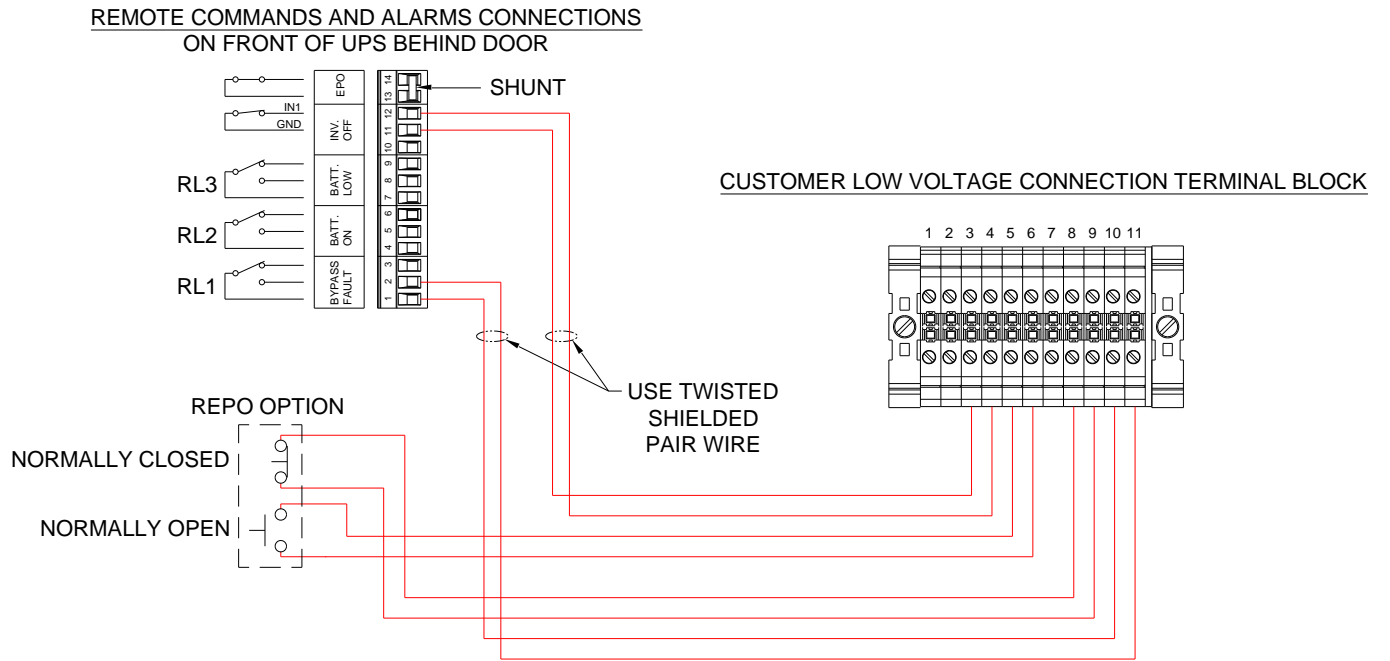

Figure 6 - Customer Low Voltage Connection Terminal Block

## SECTION 5

### Backfeed Protection

In some of the possible combinations of switch positions for the MBS, the output of the UPS could be connected to the input to the system. If the UPS is in Normal mode (the load is being supplied power from the inverter), this could cause damage to the UPS. Further, if the input to the system is not powered, the inverter could run on battery and supply voltage to the input of the system. Service personnel working on the line feeding the input to the system (or the line feeding that line, etc.) could be subjected to hazardous conditions. Imagine an electrician opening the supply breaker feeding the MBS and expecting that line to be safe to work on. A requirement for UPS design is that backfeed must be prevented. The FirstLine P UPS is listed to UL 1778 which means that backfeed protection is provided for the bypass static switch arrangement.

Since the MBS is external to the UPS, the UPS cannot provide backfeed protection without receiving information concerning the position of the switches in the MBS. An additional requirement is that backfeed protection be provided with the failure of any one component. That means that the protection must have redundancy in the method.

The redundant methods implemented in the FirstLine P MBS are as follows:

1. If the UPS Output Breaker (Breaker #3) and the Bypass Breaker (Breaker #2) are both closed, the UPS is commanded to go to Bypass mode, no matter what. If the UPS was operating on battery due to an input source failure, the load will lose power, but it will be impossible for the UPS to cause backfeed. This method requires a signal from the MBS control to the UPS control via a pair of wires.
2. Unless the UPS is On Bypass OR the UPS Output Breaker (Breaker #3) is open, the trip mechanism of the Bypass Breaker (Breaker #2) will be activated, preventing it from closing. This requires a signal from the UPS control to the MBS control via a pair of wires.

As is explained in Section 6, the proper procedure for putting the MBS into the Bypassed mode requires that the user first put the UPS in "Manual" Bypass Mode. Thus the signal that the UPS is On Bypass will be present and the Bypass Breaker in the MBS can be closed. Further, closing the Bypass Breaker will assert the command to the UPS to go to bypass, but this will have no effect as the UPS is already in bypass. That is, if the user follows the correct procedures for operating the MBS, these backfeed prevention schemes will be completely transparent.

### Remote EPO (Emergency Power Off)

Some applications (notably, data centers) require that there is a provision to remotely shut down power to the equipment powered by the UPS. Typically, this "remote" control is a red button switch located next to the exit and wired to the UPS. The FirstLine P UPS is equipped with a Remote EPO input, but this input would have no effect on the load power if

the load was being powered by the Bypass Breaker in the MBS. The FirstLine P MBS is equipped with a Remote EPO input that causes both the Bypass Breaker (Breaker #2) and the UPS Output Breaker (Breaker #3) to trip when a switch activation is sensed. This way, power is interrupted, regardless of which breaker was actually supplying current to the load. It may be desirable to also shut down the UPS upon activation of the EPO function. This requires a separate switch contact (NC) wired in accordance with the restrictions in the UPS manual.

Note that the UPS has a front panel "EPO" switch. Pressing this switch will cause the UPS to shut off immediately, but its action is only local. That is, it affects the UPS, but there is no way for this switch have a direct operating effect on the MBS. (There are some indirect possibilities. For example, stopping the UPS by pressing the EPO could cause the On Bypass signal from the UPS to the MBS to change, tripping the Bypass Breaker if the UPS Output Breaker is also closed. These indirect actions will not affect system operation if the system is operated according to the procedures in Section 6.)

Some users prefer to use a normally open switch in the REPO system; others prefer a normally closed switch. Inputs for both types of switches are provided in the FirstLine MBS, but the normally closed function has to be enabled by operating a small rocker switch on the Options Control Board. This is to avoid the problem of not being able to operate the system if the normally closed circuit is missing, as when the user only chooses to use the normally open configuration, or when the user does not choose to use the REPO system at all.

Historically, REPO systems have caused a lot of confusion due to systems not being capable of operation due to a false signal from the REPO switch(es). To address this issue, the Options Control Board has a yellow LED lamp (DS1 in the upper right corner of Figure 5) that indicates that the REPO has been activated. The logic that operates the lamp latches the indication, so it is possible to determine that the REPO was activated at some time since power was applied to the system. The latched indication can be reset by pressing S1 on the Options Control Board.

Some users prefer that power not be restored to the load automatically, if lost, so that they can manually reapply power to the connected loads using a defined sequence. There is a rocker switch on the Options Control Board that selects this capability. If the switch is ON and power is lost (both the utility input power to the cabinet and the power from the UPS), Breakers #2 and #3 will both trip, assuring that the load cannot be powered without manually closing one of these breakers. Sometimes this feature is called "Manual Restart".

## SECTION 6

### Operation

Refer to the User's Manual for the UPS for instructions on operating the UPS part of the system. **If the UPS is part of a parallel system, special operating instructions apply.**

### Maintenance Bypass Switch (MBS)

The purpose of the Maintenance Bypass Switch (MBS) is to facilitate servicing the UPS without removing power from the load. The main functional components of the MBS are three circuit breakers that are used as disconnect switches. We will designate them "BKR1", "BKR2", and "BKR3", but they are labeled "1", "2", and "3" above the breaker handles on the front inner cover of the cabinet. The breakers each have three positions: off (down), on (up), and tripped (in between off and on). To turn on a tripped breaker, reset the breaker by pushing the handle down to the off position, then raise it to the on position. If a breaker will not reset or trips as being turned on, the backfeed prevention interlock is active and the proper conditions (as described below) will have to be present before the breaker can be operated. When closed, BKR1 supplies power from the supply (utility) to the bypass input of the UPS. For single input UPS configurations, it also supplies power to the rectifier input. When closed, BKR3 connects the output of the UPS to the load. When closed, BKR2 bypasses the path through BKR1, the UPS, and BKR3 and connects the supply directly to the load. BKR2 and BKR3 must never be closed at the same time unless the UPS is in bypass mode. It does not matter which type of bypass, but bypass via SWMB is the simplest to engage. There are signals that support an interlock function to prevent BKR2 from being closed unless BKR3 is open or the UPS is in bypass mode. For the UPS to be able to issue this signal, the UPS controls must be powered. Always observe proper switching sequence to avoid loss of power to the load. Common switching operations are also described, below. There are also some problem scenarios listed.

The three switches (Breaker 1, Breaker 2, and Breaker 3) have eight possible combinations or "States". Table 6 lists all of the possible states. Note that one possibility (Breaker 1 open, Breaker 2 and Breaker 3 closed) is forbidden as unexpected system behavior could result, including loss of power to the load. The Overlap State is a transient state. It is the "make" before the "break". Time spent in this state should be kept to a minimum as external events could lead to tripping Breaker 2, possibly interrupting power to the load. Also, please note that the UPS does not condition the power to the load while in bypass and that battery back-up is not available while in bypass.

To avoid damage to the UPS and to avoid interrupting power to the load, the procedures listed in Table 7 must be used to change from one state to another. The MBS is equipped with a label (see Figure 7) that describes the breaker sequences for two common operations. The "To place load on maintenance bypass" sequence describes going from Normal State to Overlap to UPS Unloaded to Maintenance. The "To place load on UPS" sequence describes going from Maintenance State to UPS Unloaded to Overlap to Normal.

**Common MBS operations: (refer to the UPS manual for UPS operations; BKR1, BKR2, BKR3 are part of the Maintenance Bypass Switch Cabinet; all other switches are part of the UPS)**

**To transfer from normal mode on the UPS to maintenance bypass—**

1. Verify that the bypass source is satisfactory: at minimum, verify that the bypass source lamp (LED1 at upper left) on the front panel of the UPS is steady green and that the legend “BYPASS VOLTAGE FAIL” is not present on the display. If the load is already being supported by the Static Bypass, the yellow “Load on Bypass” lamp (LED4, upper right) will be steady (or flashing if the load exceeds the UPS rating). Refer to Section 6 of the UPS manual regarding the indicators.
2. Close SWMB on the UPS. After SWMB is closed, the yellow “Load on Bypass” lamp will flash and the inverter will stop and battery supported operation is no longer possible.
3. Close BKR2.
4. Open BKR3.
5. Shut down the UPS, if desired, by opening SWOUT, SWIN, SWBY, and open the Battery Disconnect(s). Optionally open SWMB.
6. If the UPS is shut down, open BKR1. The UPS is completely de-energized at this point.

**To transfer from MBS to normal mode—**

1. Close BKR1.
2. On the UPS, verify that SWMB is closed, if not, close it.
3. Close SWBY, SWIN, and SWOUT. Wait 5 seconds.
4. Close BKR3.
5. Open BKR2.
6. Open SWMB. The UPS should start and operate normally.
7. When the display no longer shows: “Wait: DO NOT connect the BATTERY”, the disconnect breakers in each battery cabinet should be closed. Refer to Section 4.6 for the proper procedure for connecting the battery.

**Normal start-up with load unpowered—**

1. Verify that BKR2 is open; open it if closed.
2. Verify that SWBY is open.
3. Close BKR1 and BKR3.
4. Perform a normal UPS start-up as per Section 4.6 of the UPS manual.

**Need to get power to the load, but the condition of the UPS is uncertain—**

1. Verify that the load is truly not powered.
2. Verify that the utility source is suitable (applying power to the load using the MBS is at the operator's risk).
3. Verify that BKR1 and BKR3 are open; open them if necessary.
4. Close BKR2. The load is now powered via the MBS. The UPS is not functional and battery supported operation is not possible.

**Need to operate the UPS as part of maintenance, but wish to maintain power to load—**

1. If UPS is running, perform transfer from normal mode to MBS, as instructed, above. After opening BKR3, the UPS can be left powered (via BKR1) and/or its mode can be changed as desired.
2. If BKR2 is already closed, close BKR1 to apply power to the UPS. If the UPS is dual input, there is another supply that must be applied to power the rectifier.
3. There is some risk in starting the UPS while the load is powered via BKR2 (MBS mode). A fault in the UPS could cause the upstream circuit protection (circuit breaker or fuse) to operate, removing power from both the faulted UPS input and the MBS input and, therefore, the output.

**Potential Problems:**

**MBS will not allow BKR2 to close—**

1. Check to see that the UPS is on bypass (SWMB is closed).
2. The UPS controls must be powered (BKR1 and SWBY should be closed).
3. Verify that the backfeed prevention interlock signals were properly wired as part of the installation and that this wiring has not been damaged.

**BKR2 in the MBS trips when power is applied—**

1. This is likely due to a procedural error. Note that BKR2 and BKR3 must not be closed at the same time unless the UPS is powered and the UPS is in bypass mode.
2. It is likely that BKR3 is closed and the backfeed prevention interlock function is preventing BKR2 from staying closed.
3. Since the UPS is not powered, the signal that indicates that the UPS is in bypass mode cannot be generated.
4. Open BKR3 and close BKR2. BKR2 should close and stay closed.
5. If power to the UPS is not required, open BKR1.

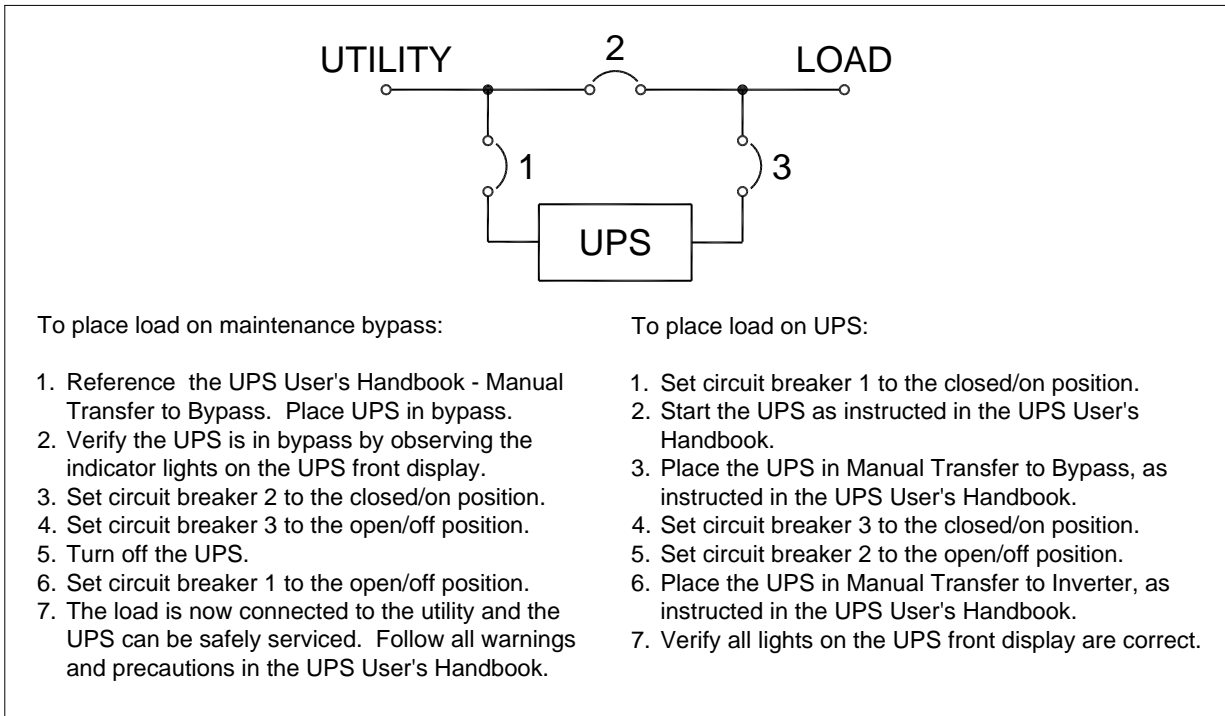

**Figure 7 - Circuit Breaker Sequence Label**

## REPO

User provided switch circuits are required to activate the REPO. Upon activation, the REPO function trips Breaker 2 (if closed) and Breaker 3 (if closed), interrupting power to the load. For details on how to connect to the REPO input(s) refer to Section 4 of this Manual.

To restart the system after activation of the REPO, make sure that the REPO switch is in the non-activated state before continuing. Then, use the Startup procedure for the MBS.

**Table 6 - Maintenance Bypass Switch States**

Breaker 1 = Left hand breaker = UPS Input  
 Breaker 2 = Center breaker = Bypass  
 Breaker 3 = Right hand breaker = UPS Output

<b>State Name</b>	<b>Breaker 1</b>	<b>Breaker 2</b>	<b>Breaker 3</b>	<b>Adjacent State(s)</b>
Normal	closed	open	closed	Overlap, Test UPS, Test Battery
Overlap	closed	closed	closed	Normal, UPS Unloaded
UPS Unloaded	closed	closed	open	Overlap, Maintenance
Maintenance	open	closed	open	UPS Unloaded, Load Off
Load Off	open	open	open	Maintenance, Test UPS
Test UPS	closed	open	open	Load Off, Normal
Test Battery	open	open	closed	Normal
Not Allowed	open	closed	closed	(none)

**Table 7 - Maintenance Bypass Switch State Change Procedures**

(refer to Table 8 for description of states)

<b>From State</b>	<b>To State</b>	<b>Procedure</b>
Normal	Overlap	1. Select Manual Bypass Mode on UPS. 2. Verify load on bypass by observing front panel of UPS. 3. Close Breaker 2.
Overlap	Normal	1. Open Breaker 2. 2. Select Automatic Transfer to Inverter Mode on UPS.
Overlap	UPS Unloaded	Open Breaker 3.
UPS Unloaded	Overlap	1. Select Manual Bypass Mode on UPS. 2. Verify load on bypass by observing front panel of UPS. 3. Close Breaker 3.
UPS Unloaded	Maintenance	1. Turn Off UPS 2. Open Breaker 1.
Maintenance	UPS Unloaded	1. Close Breaker 1. 2. Turn On UPS
Maintenance	Load Off	Open Breaker 2. (This removes power from load!)
Load Off	Maintenance	Close Breaker 2.
Load Off	Test UPS	1. Close Breaker 1. 2. Turn On UPS, if desired.
Test UPS	Load Off	1. Turn Off UPS. 2. Open Breaker 1.
Test UPS	Normal	1. Turn Off UPS. 2. Close Breaker 3. 3. Turn On UPS.
Normal	Test UPS	Open Breaker 3. (This removes power from load!)
Normal	Test Battery	Open Breaker 1. Battery will discharge while Breaker 1 is open.
Test Battery	Normal	Close Breaker 1.

## **SECTION 7**

### **Maintenance**

There are no wear items in the MBS that require periodic replacement. However, regular care will assure maximum availability of power.

Keep the ventilation openings in the cabinet free of dust and debris.

Wipe the cabinet exterior with a soft cloth, slightly dampened with water, to remove dust.

Consider performing periodic infrared temperature measurements on the circuit breaker terminations. This will require access to the cabinet interior. There are hazardous voltages present and any work must be performed using caution. Only trained service personnel should perform this work. Elevated temperatures of the terminations usually are the sign of a loose connection, but can also signal that a breaker is failing. Loose connections should only be serviced after removal of power.

If the system is powered down, consider removing accumulated dust from the cabinet interior using a vacuum cleaner.

**SECTION 8**

**FirstLine P Maintenance Bypass Switch Technical Specifications**

**Table 8 - Technical Specifications**

<b>Environmental</b>			
Altitude	De-rate load capability above 1000 meters 1% per 100 meters.		
Operating Temperature	40° C Maximum		
Humidity	Maximum 95%RH, Non-condensing		
<b>Electrical</b>	<b>80kVA</b>	<b>100kVA</b>	<b>125kVA</b>
Rated voltage	480/277	480/277	480/277
Rated Current	109A	136A	160A
Breaker Rating	150A	175A	200A
Minimum Wire Size	INPUT	2/0 AWG	3/0 AWG
	OUTPUT	1/0 AWG	2/0 AWG
Heat Rejection – Less than (BTU/Hr)	800	1000	1250