



Tower
Battery Bank Installation
User's Manual

Table of Contents

Chapter 1.	Important Safety Instructions	2
Chapter 2.	Introduction to the Rear Panel	4
2.1.	Rear Panel Descriptions	4
Chapter 3.	Installation and Operation	5
3.1.	Unpacking	5
3.2.	Selecting Installation Position	6
3.3.	Installation Instructions.....	7
3.4.	Storage Instruction	9
Chapter 4.	Optional Battery Bank Connections	10
4.1.	Types of Chargers Installed	10
4.2.	Explanation of the connection among the internal UPS, UPS to Battery Bank 1 and Battery Bank 1 to Battery Bank 2	10

Chapter 1. Important Safety Instructions

SAVE THESE INSTRUCTIONS

This manual contains important instructions that should be followed during installation and maintenance of the battery bank and batteries.

An Important Notice

- The battery bank which is supplied with a factory input plug can be safely connected to the wall receptacle by the user.
- This battery bank is connected to an UPS. There will be voltage at the output terminals if the UPS is turned on even if the input AC mains is not available.
- Make sure that the AC utility outlet is correctly grounded.
- Do not try to repair the unit yourself, contact your local supplier or your warranty will be void.
- Use a certified input power cable with the correct plugs and sockets for the appropriate voltage system.
- To eliminate any overheating of the battery bank, keep all ventilation openings free from obstruction and do not place any foreign objects on top of the battery bank. Keep the battery bank 20 cm away from the wall.
- Make sure the battery bank is installed within the proper environment as specified. (0-40°C and 30-90% non-condensing humidity)
- Do not install the battery bank under direct sunlight. Your warranty will be void if the batteries fail due to overheating.
- This battery bank is designed for indoor use only.
- This battery bank is not designed for use in dusty, corrosive and salty environment.
- The warranty for this battery bank will be void if water or other liquid is spilt or poured directly onto the battery bank. Similarly we do not warrant any damage to the battery bank if foreign objects are deliberately or accidentally inserted into the battery bank enclosure.
- The battery will discharge naturally if the system is unused for a period of time.
- It should be recharged every 2-3 months if unused. If this is not done, then the warranty will be null and void. During normal operation, the batteries will be automatically remained in charged condition.

- Servicing of batteries should be performed or supervised by trained personnel with knowledge of batteries and the required precautions
- When replacing batteries, replace with the same quantity, type & capacity.
- CAUTION – Do not dispose of battery or batteries in an open fire. The battery may explode.
- CAUTION – Do not open or mutilate the batteries. The electrolyte from the batteries is toxic and harmful to the skin and eyes.
- CAUTION – Risk of electric shock – battery circuit is not isolated from AC, hazardous Voltage may exist between battery terminals and ground. Test before touching with bare hands.
- CAUTION – A battery can present a risk of electrical shock and high short circuit current. The following precaution should be observed when working on batteries:
 - A. Remove watches, rings, or other metal objects.
 - B. Use tools with insulated handles.
 - C. Wear rubber gloves and boots.
 - D. Do not lay tools or metal parts on top of batteries.
 - E. Disconnect charging source prior to connecting or disconnecting battery terminals.

Chapter 2. Introduction to the Rear Panel

2.1. Rear Panel Descriptions

SC-BP1000
SC-BP2000

SC-BP3000

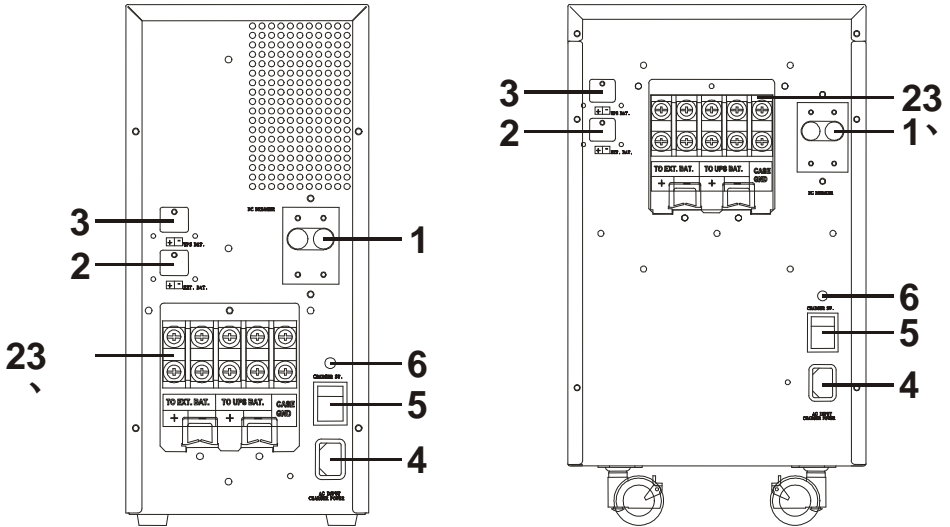



<p>1. DC Breaker</p>	<p>1. Battery Over-current Protection Breaker 2. To easy swappable battery, please put the position of the breaker in “O” position. In case there is 2nd(or next) battery bank connected with the battery bank, the DC voltage from the UPS Bat.+/- will flow through without any interruption to the 2nd Battery Bank.</p>
<p>2. EXT.BAT. +/-</p>	<p>To the DC terminal of the 2nd(or next) battery bank connected.</p>
<p>3. UPS BAT. +/-</p>	<p>To the UPS DC terminal</p>
<p>4. Charger Inlet</p>	<p>The inlet of the charger built-in the Battery Bank.(Optional)</p>
<p>5. Charger Switch</p>	<p>To control the On/Off switch of the charger.(Optional)</p>
<p>6. Utility Indicator</p>	<p>To show the Utility is flown through the charger.(Optional)</p>

Chapter 3. Installation and Operation

3.1. Unpacking

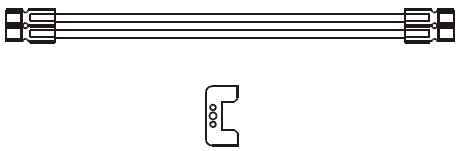
1. Take the battery bank out of the PE foam.
2. Remove the packing materials.
 Note: The battery bank module is approx. 12.5~50 kgs, be cautious when unpacking and lifting the unit to avoid injury.
3. Standard Package includes:
 - a. User's Manual
 - b. DC connect cable
 - c. AC Input Power Cord (for charger only)
4. Accessories for Tower and Rack Mount

UPS	CONNECTION
SC1000 115V/230V SC2000 115V/230V SC3000 115V/230V	 <div style="display: flex; justify-content: space-between; align-items: center;"> <div style="text-align: right;">1 pcs</div> </div> <div style="display: flex; justify-content: center; align-items: center; margin-top: 20px;">  <div style="text-align: right; margin-left: 20px;">2pcs</div> </div>

Note: The packing condition and the external outlook of the unit should be inspected carefully before installation. Retain the packing material for future use.

3.2. Selecting Installation Position

It is necessary to select a proper environment to install the unit, in order to minimize the possibility of damage to the battery bank and extend the life of the batteries. Please follow the instructions below:

1. Keep at least 20cm (8 inches) clearance from the rear panel of the battery bank from the wall or other obstructions.
2. Do not block the air-flow to the ventilation openings of the unit.
3. Please ensure the installation site environmental conditions are in accordance with the battery bank working specifications to avoid overheat and excessive moisture.

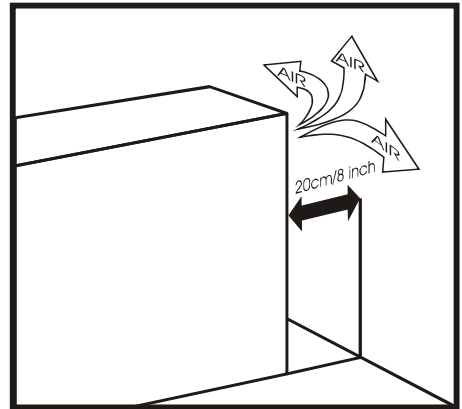

4. Do not place the battery bank in a dusty or corrosive environment or near any flammable objects.
5. This battery bank is not designed for outdoor use.

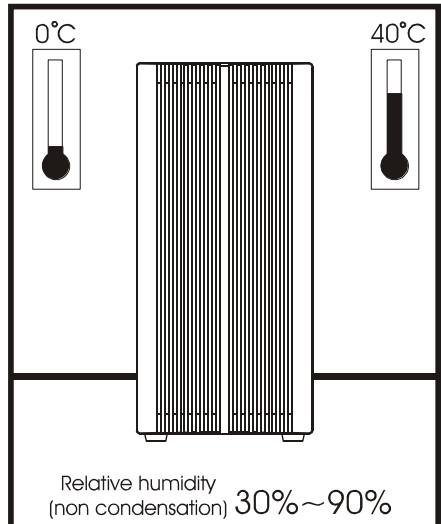

3.3. Installation Instructions

- 1. For UPS : SC1000 115V/230V
SC2000 115V/230V
SC3000 115V/230V

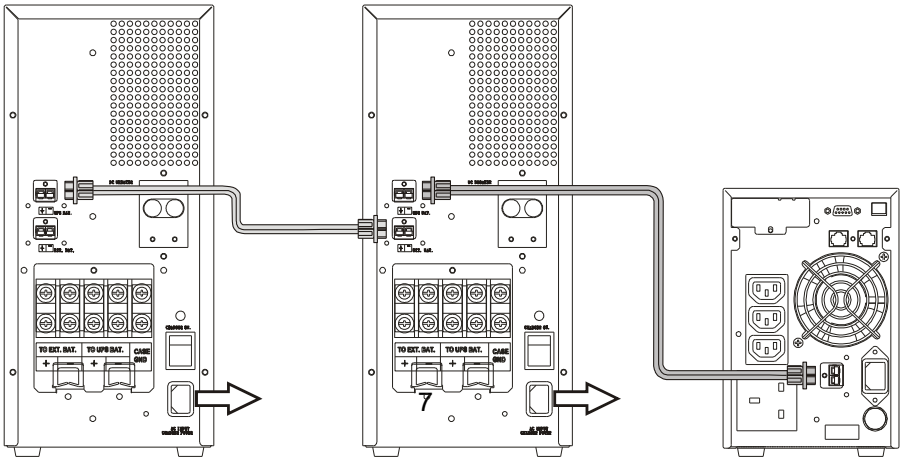
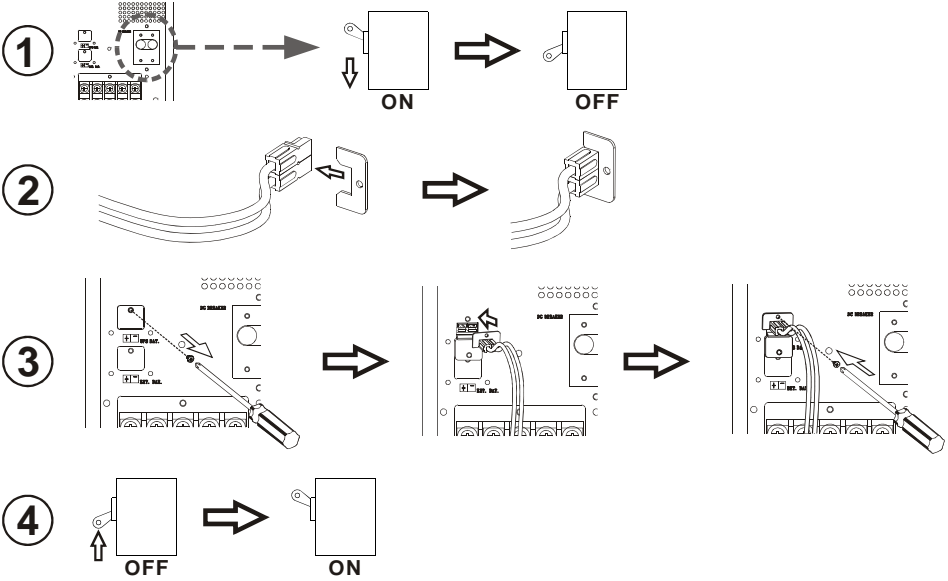

Connect to Utility
(Charger Included)

Connect to Utility
(Charger Included)

Second Battery Bank

First Battery Bank

UPS

3.4 Storage Instruction

For extended storage through moderate climate(-15 to +30 °C / +5 to +86 °F), the batteries should be charged for 12 hours every 6 months by plugging the UPS power cord into the wall receptacle. Repeat this every 3 months under high temperature (+30 to +45 °C / +86 to +113 °F) environment.

Chapter 4. Optional Battery Bank Connections

4.1. Types of Chargers Installed

Charger Type	Part No.	Application	Wire connection			
			Position(F)	Position(G)	Position(H)	Position(I)
200W	CHCC2xx	SC1000, SC2000, SC3000,	16AWG Brown Wires P/No.0469	16AWG Blue Wires P/No.0431	12AWG Red Wires P/No.0302	12AWG Black Wires P/No.1869
500W	CHAC0xx, or CHR500-x	SC2000, SC3000,	16AWG Brown Wires P/No.0469	16AWG Blue Wires P/No.0431	12AWG Red Wires P/No.0302	12AWG Black Wires P/No.1869

4.2. Explanation of the connection among the internal UPS, UPS to Battery Bank 1 and Battery Bank 1 to Battery Bank 2

2. MS Series in Tower types			
SC1000	Installation is done	Installation is done	12AWG Red/Black Wires P/No. 1892
SC2000	Installation is done	Installation is done	12AWG Red/Black Wires P/No. 1892
SC3000	Installation is done	Not Necessary	12AWG Red/Black Wires P/No. 1892

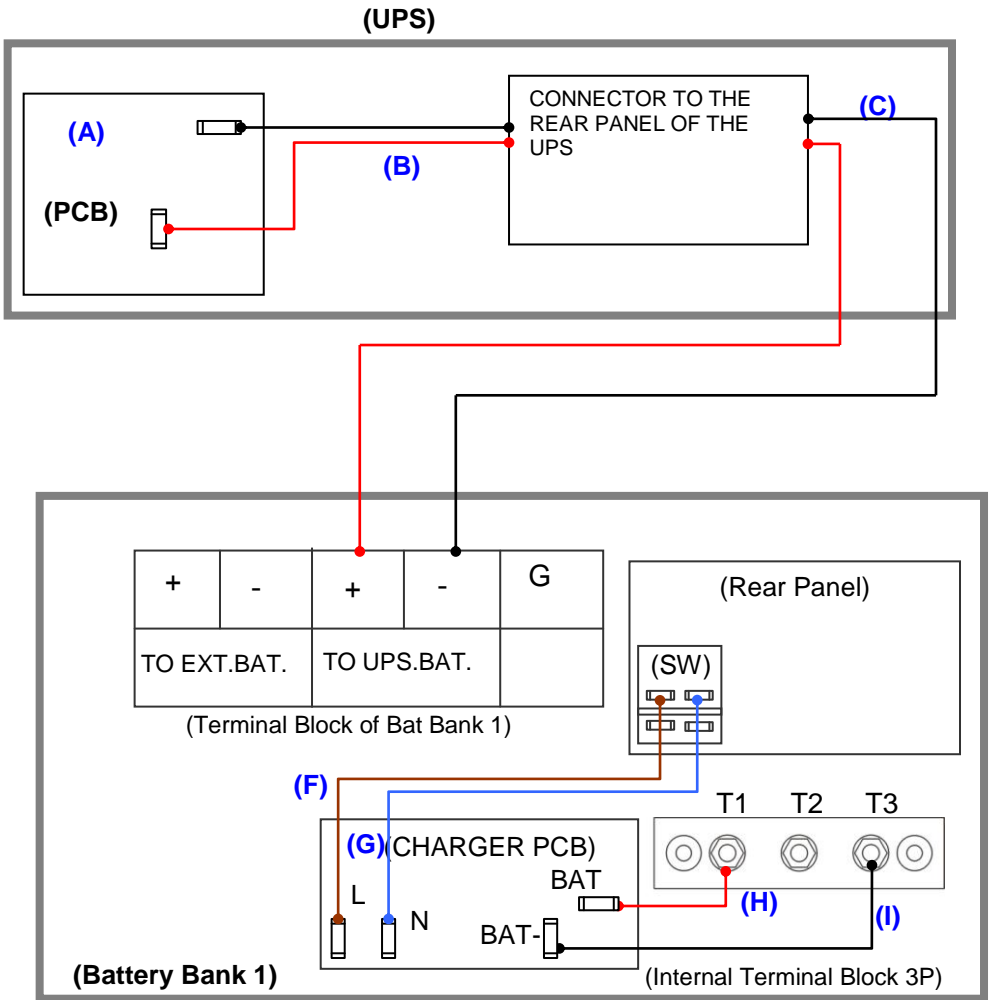

Wire 1892



Wire 1990 & 2777 Red and Wire 1991 & 2778 Black

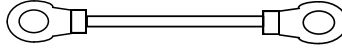

Wire 0469 Brown

Wire 0431 Blue

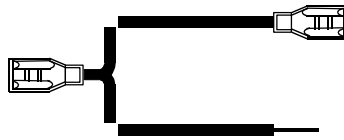

Wire 0302 Red Wire 1869 Black

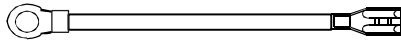

Board P/N	L	N	Bat+	Bat-
CHCC2X	CN10	CN11	CN6	CN5
CHAC0-X	CN1	CN2	CN7	CN6
HAS-C2xx	CN404		CN6	CN5